

StarLight series

FEMTOSECOND LASER OPERATION MANUAL

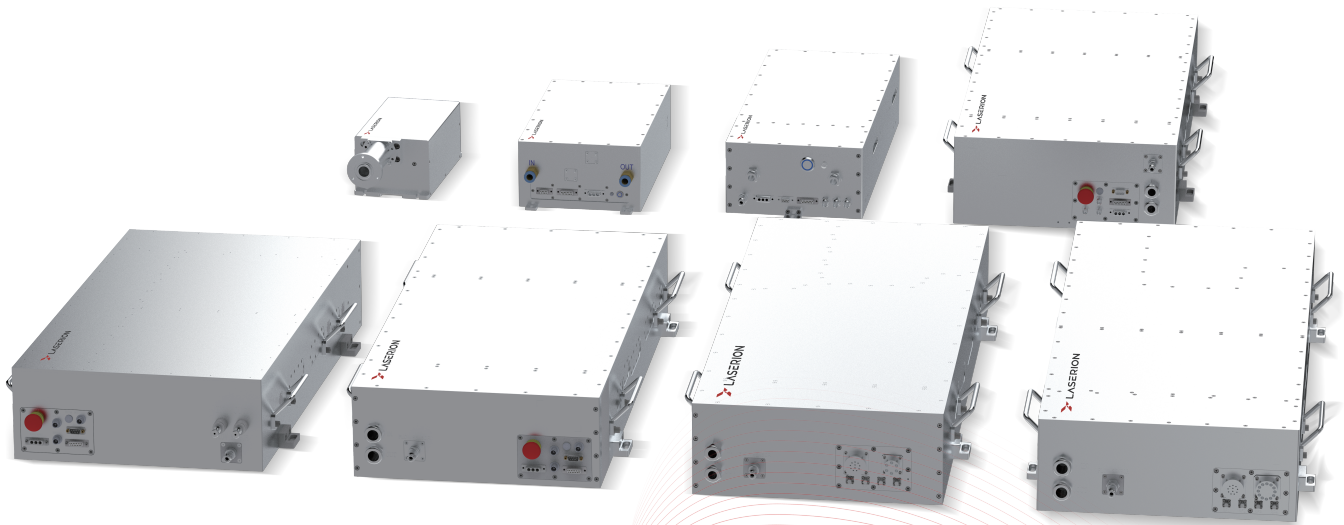

CONTENTS

1、Precaution	3
2、Power Connection	3
3. Equipment Composition	3
3.1 Split Structure	3
3.2 Integrated Structure	4
4. Signal Connection for the Complete Unit	6
5. Expansion Interface	9
5.1 Split machine	9
5.2 IntegratedMachine	10
5.3 I/O Interface Important Notes	11
6. Startup Steps	12
7. Mode Description	13
8. Signal Connection Between Laser and Control Card	15
8.1 All-in-one machine signal connection	15
8.2 Signal Connection for Split-type Machine	16
9. Simple Operation Instructions for Host Computer Software ...	16
10.Common Fault Table	27

Precautions ATTENTIONS

- * Please refer to the 《 Detailed Specifications 》to select the appropriate power supply.
- * Please refer to the《 General Safety Instructionsto》 check whether the peripheral working configuration environment of the laser meets the requirements.
- * Do not crush or excessively bend the external water pipes and cables of the laser.

Power Connection POWER CONNECTION

The power supply voltage of the laser equipment is single-phase alternating current 220V AC. Ensure that the live wire, neutral wire and ground wire are correctly connected according to the wire labels. Poor contact of the ground wire may cause potential damage to the laser.

To ensure safety, it is strongly recommended that you connect a circuit breaker (air switch) and a voltage stabilizer in series between the power supply unit and the laser power socket. The circuit breaker facilitates wiring operations.

Device Composition EQUIPMENT COMPOSITION

The complete laser equipment is available in ****split type**** and ****all-in-one type**** depending on the product model.The split type consists of a laser, an electric control cabinet, and a water chiller.The all-in-one type consists of a laser, a power supply, and a water chiller.Under normal conditions, the laser, electric control cabinet, and power supply are provided by our company as follows:

* Split Structure



* Front view of the laser equipment



* Rear view of the laser equipment



* Front panel of the electric control cabinet



* Rear panel interfaces of the electric control cabinet

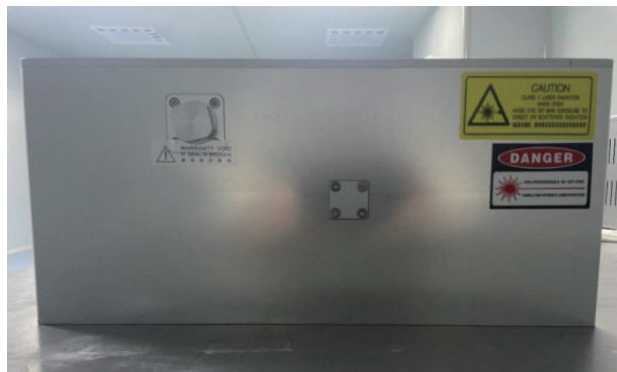

* Front panel of the laser



* Rear panel of the laser

*** All-in-one structure**



* Front view of the laser equipment

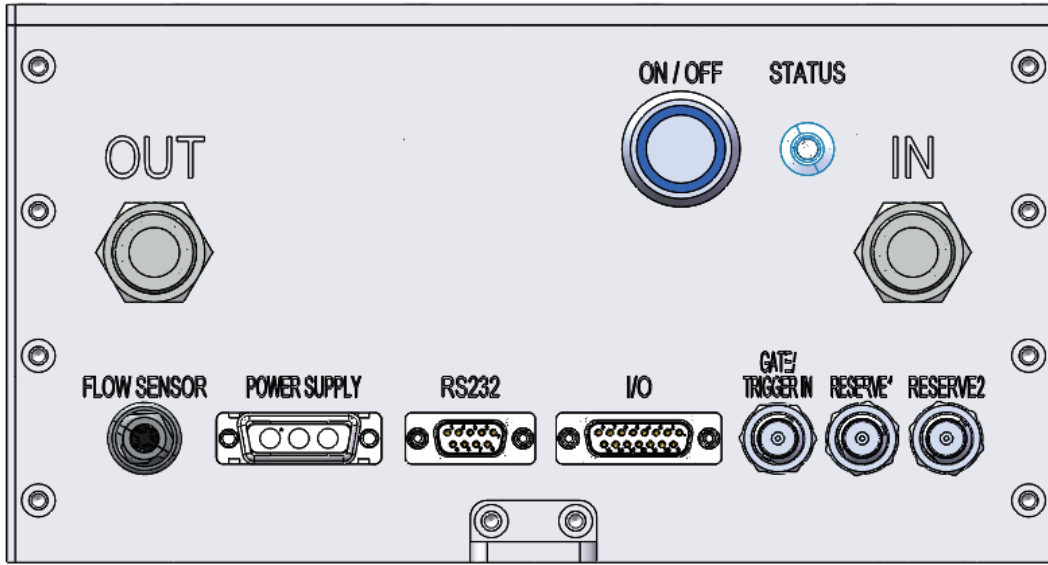

* Front appearance 1 of the laser



* Front appearance 2 of the laser

Signal connection of the complete equipment

COMPLETE MACHINE EQUIPMENT SIGNAL CONNECTION

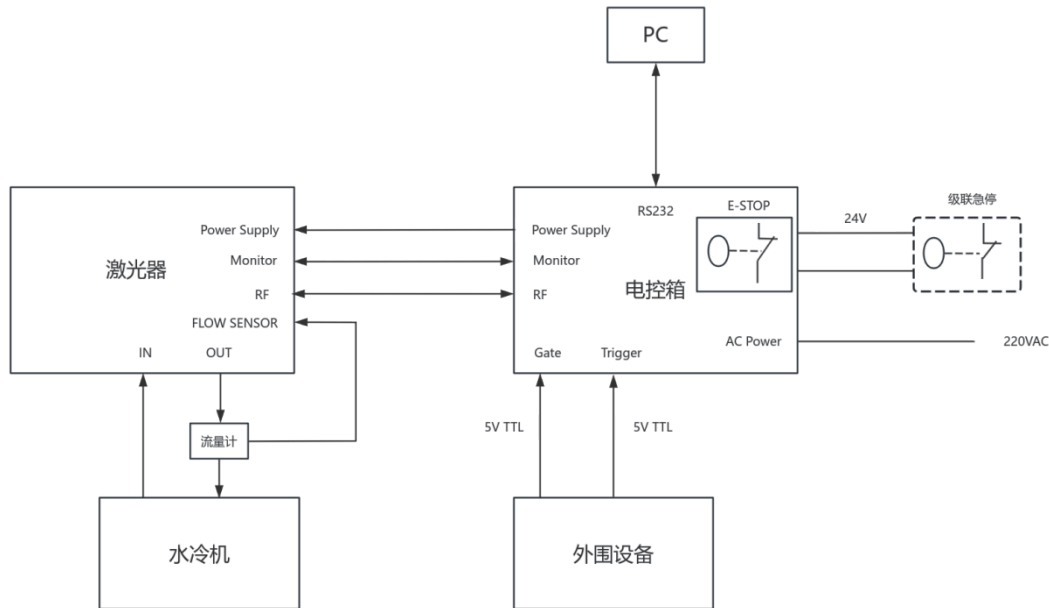

*Schematic diagram of split-type connection

1. Connect the 55-pin and 6-pin / 12-pin aviation connectors between the laser and the electric control cabinet (interfaces vary slightly for different products). Connect the corresponding RF cables according to the instructions on the RF labels.
2. If the rear panel of the laser is equipped with a dedicated flow meter interface (FLOW SENSOR), please insert the flow meter plug. (The flow meter is enabled by default, and two are supplied as consumables with the equipment. If you need to disable the flow meter, please confirm with the sales personnel in advance. When connecting to the water chiller, ensure the arrow on the flow meter is consistent with the water flow direction.)
3. For models without a dedicated flow meter interface, connect the flow meter to the 3P connector from the 55-pin aviation plug. For this version of the laser, pay attention to the labels on the 55-pin aviation plug to distinguish the **laser side** from the **electric control cabinet side**.
4. Check that the E-STOP interface of the electric control cabinet remains short-circuited. For usage details, refer to the I/O interface chapter below.
5. For lasers with I/O functions, a DB9 male connector with INTERLOCK short-circuited is supplied with the equipment. Check that the DB9 male connector is inserted into the I/O interface of the electric control cabinet. For usage details, refer to the I/O interface chapter below.
6. Front appearance 1 of the laser* Front appearance 2 of the laser
7. According to process requirements, connect the machine's processing signal to the GATE or TRIGGER interface.

* Brief Description of External Signals

AC Power Laser power input: Connect to external 220V AC. A 0250V 10A AC fuse is already installed inside the electric control cabinet. We strongly recommend connecting a circuit breaker (air switch) and a voltage regulator in series between the power supply unit and the laser power socket for convenient wiring and operation.

GATE : External GATE signal connection to processing equipment: 5V TTL.

TRIGGER : External trigger signals such as TRIGGER/PSO/POD connected to processing equipment: 5V TTL. The input signal frequency should be lower than the set repetition frequency of the laser.

RESERVE: This is a reserved interface for external power adjustment, supporting 0–10V or 0–5V input. Please contact our company for confirmation if you require this function.

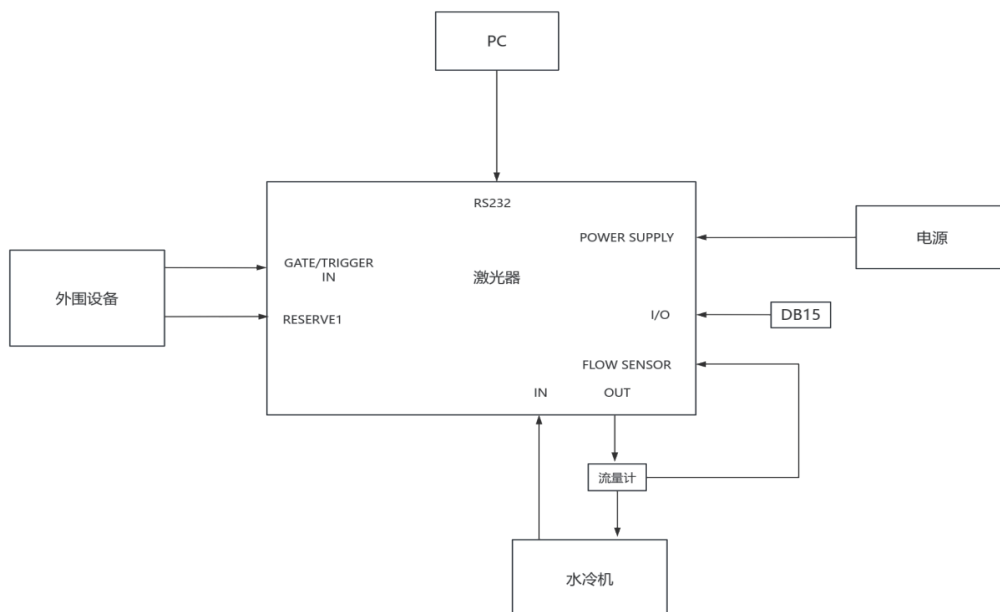

*Schematic Diagram of All-in-One Connection

1. Connect the input terminal of the switching power supply to 220vAC, and connect the output terminal to the laser's POWERSUPPLY. The output cable label at the output terminal is marked as V+V- ground. To ensure good grounding for the laser, a ground wire has been reserved at the power output end; it is recommended to extend and directly connect to ground.
2. Insert the flow meter plug into the FLOW SENSOR interface. (The flow meter is enabled by default and can be considered as an easily damaged part shipped with two units; if you have requirements for shielding the flowmeter function, please confirm with sales personnel in advance. When connecting to the water-cooled machine, ensure that the arrow direction of the flow meter aligns with the flow direction.)
3. Insert the included DB15 male connector; it is default short-circuited with cascade emergency stop and INTERLOCK; refer to the I/O interface section below for usage.
4. Insert the communication cable into the RS232 port and operate the control software.

* Brief Description of External Signals:

STATUS: When the status indicator light flashes yellow, it is preparing for output; flashing green indicates the process of turning on or off the light constantly lit means currently emitting light; red steady-on or flashing indicates a fault. Please check the cause of the fault on the upper computer or contact our after-sales service.

GATE/TRIGGER: External signal connected to machining equipment. The Gate signal is 5V TTL; TRIGGER connects to trigger signals from machining equipment such as TRIGGERIPSo\POD, 5V TTL, and the input frequency should be lower than the set laser repetition rate. Processing mode must be selected and switched via the host computer.

RESERVE1: This interface is reserved and can be used for external power regulation with 0-10V or 0-5V input. Please confirm with sales personnel if this function is required.

Expansion Interface EXPANSION INTERFACE

The Laser I/O interface is a high-quality, easy-wiring DIB9 (dual unit) /DB15 (single unit) interface that provides multiple signals for laser function control, as described below:

1. Split machine

DB9 Number	Identifie	introducti
1	0V	Used for signal common ground; do not connect to any non-0V/GND pins.laseris alarming.
2	Laser Alarm StatusIndicator	SVNPN signaloutput (0V). Used to indicate whether the laseris alarming.
3	Laser emission statusindicator	5V NPN signaloutput (0V). Used to indicate whether the laser has been activated (on).
4	Motion Enable Status Indication	5V NPN signal output (0V). Used to indicate whether the laser is stable, so that the processing equipment can start moving and perform processing.
5	Interlock 1	Dry contact; when not in use, short-circuit with 'Interlock 2'; failure to short-circuit will lock the laser. Do not connect to other pins.
6	5V	Used for signal power supply; do not connect to any 0V GND\PE pin.
7	Enable Light Gate	5V PNP signal input (5V) for turning on/off the light gate.
8	Turnon Laser	5V PNP signal input (5V), used for enabling/disabling laser.
9	Interlock2	Dry contact: When not in use, short-circuit with 'Interlock 1'; failure to do so will lock the laser. Do not connect to other pins.

2.IntegratedMachine

DB15 Number	Identifier	Description
1	Interlock 1	Dry contact; when not used, short-circuit with 'Interlock 2'; failure to short-circuit will lock the laser. Do not connect to other pins.
2	Stop quickly1	Dry contact, short circuit to 'Emergency Stop 2' when not used; failure to short circuit will trigger laser emergency stop. Do not connect to any other pin.
3	INTERLOCK status indicator	5V NPN signal output (0V). Used to indicate internal INTERLOCK status.
4	Motion Allowance Status Indicator	5V NPN signal output (0V). Used to indicate whether the laser is stable, allowing the machining equipment to start moving and begin processing
5	Laser emission status indicator	5V NPN signal output (0V). Used to indicate whether the laser has been activated (on).
6	Laser Alarm Status Indicator	5V NPN signal output (0V). Used to indicate whether the laser is alarming.
7	5V	Used for signal power supply; do not connect to any OWGND\PE pin.
8	5V	Used for signal power supply; do not connect to any OWGND\PE pin.
9	Interlock 2	Dry contact; when not used, short-circuit to 'Interlock 1'; failure to short-circuit will lock the laser. Do not connect to other pins.
10	Emergency stop 2	Dry contact; when not in use, short-circuit to 'Emergency Stop'; failure to short-circuit will trigger the laser's emergency-stop. Do not connect to any other pin.
11	Backup Input	5V PNP signal input (5V).
12	Enable Laser	5V PNP signal input (5V), used for turning on/off laser.
13	Enable Light Gate	5V PNP signal input (5V), used for turning on/off the light gate.
14	0V	Used for signal common ground; do not connect to any non-0V/GND pins.
15	0V	Used for signal common ground; do not connect to any non-0V/GND pins.

3. Important Notes on I/O Interface

E-STOP: E-STOP: This interface can be used by users to connect additional cascaded emergency stop switches; when the circuit is closed, the laser can operate normally; when the circuit is open, it triggers an emergency stop for the laser, stopping light output!

INTERLOCK: When short-circuited, normal laser emission is allowed; when disconnected, the laser will be locked and laser emission is prohibited! Note: When the INTERLOCK is disconnected, you can still operate to turn off the laser, but you cannot turn it on again.

Motion Enable Status Indicator: This pin can be used in conjunction with pin 6 (split machine), or pins 7 or 8 (all-in-one machine). When the laser is emitting light normally, 5V and 0V can form a circuit with the external processing equipment's suction switch; when no light is emitted this signal disappears, and the processing equipment can use this signal to associate motion and stop functions with the equipment

Enable Laser: This pin can be used with pin 6 (separate unit) or pins 7 or 8 (built-in unit). When a switch device is added between 5V and this pin, the laser will turn on when 5V is connected to this pin without any fault.

Enable Light Valve: This pin can be used in conjunction with pin 6 (split unit) and pin 7 or 8 (all-in-one unit). When an electronic switch is added between 5V and this pin, the laser will activate the light valve and release laser when 5V and this pin are connected. (This function requires the laser to have an internal light valve structure.)

The above functions are by default enabled only for E-STOP and INTERLOCK. The remaining descriptions are customized for certain customers. If you wish to enable these functions or customize other features, please confirm in advance with our sales personnel!

Startup Steps STARTUP STEPS

Warning:

- * Before use, ensure all electrical connections (including water pipes) are connected. If conditions permit, all connectors must be tightened and secured with screws.
- * Do not look directly at the laser output port while operating the laser and wear safety goggles strictly.
- * When performing wiring operations, please first turn off all power switches of the laser device.

The startup/shutdown procedure is as follows:

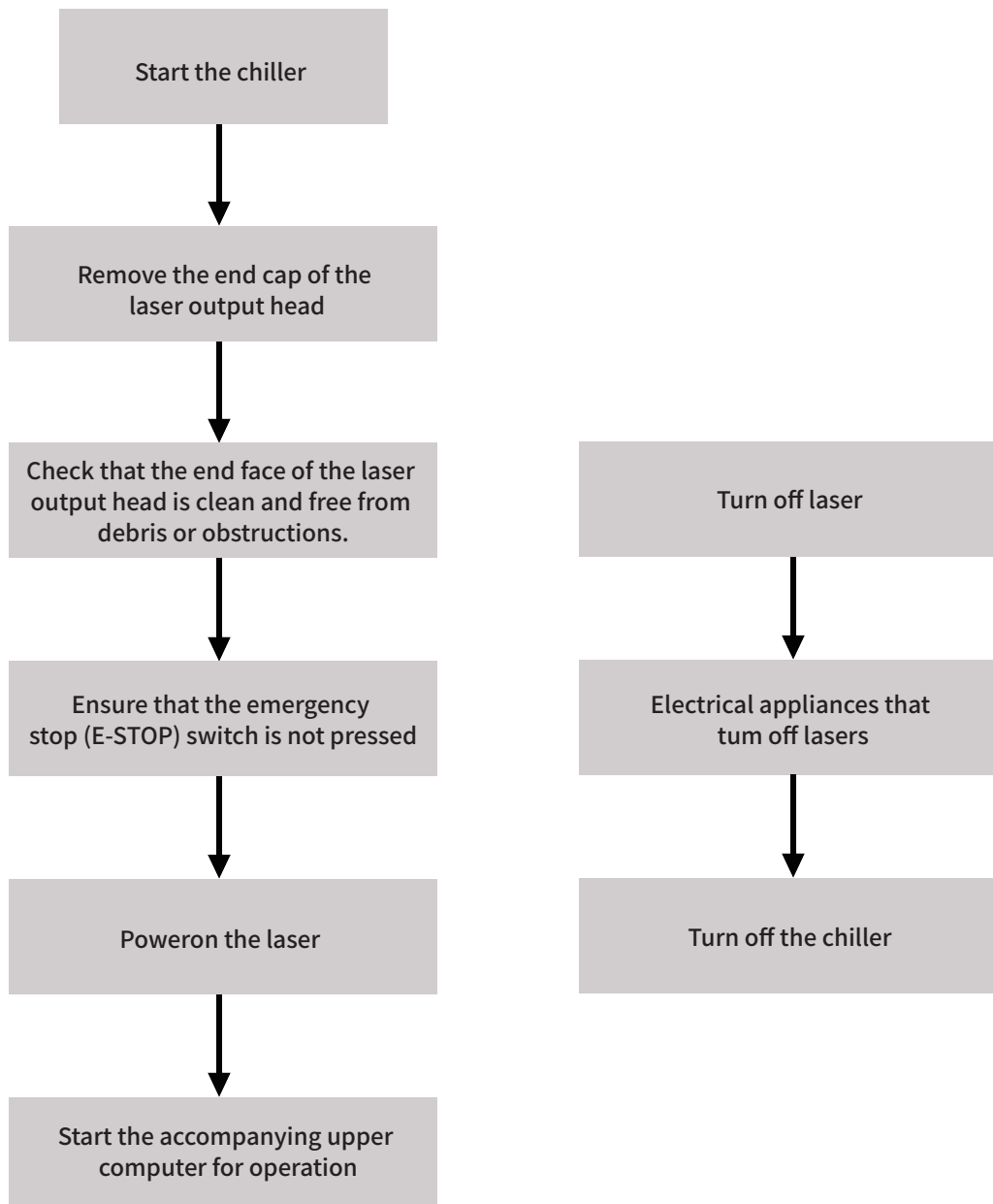

Mode Description STARTUP STEPS

The working modes of the laser are as follows:

- 1、Standby Mode: AOM is in standby mode and output signal is disabled
- 2、Internal Control Mode: AOM outputs control signals based on internal signal inputs to control laser output.
- 3、Gate Mode: When the Gate signal is high, AOM outputs control signals based on internal signals to control laser output.
- 4、Trigger Normal Mode: After the rising edge of the Trigger signal, AOM outputs control signals based on internal signals to control laser output.
- 5、Trigger Average Mode: After the rising edge of the Trigger signal, AOM outputs control signals based on internal signals to control laser output.
- 6、Trigger Compensation Mode: After the rising edge of the Trigger signal AOM outputs control signals based on internal signals to control laser output
- 7、Forced Normally Open Mode: AOM directly forces output signal regardless of presence or absence of external and internal signals.

Note:

① Due to the asynchronous timing between external input signals and laser internal signals, there may be a maximum period of jitter between laser output pulses and input signals, corresponding to one laser frequency cycle. To eliminate this effect and match market drive boards, the internal algorithms for the three Trigger modes differ; please select based on actual performance.

② The frequency of the external Trigger signal must be less than the set laser frequency.

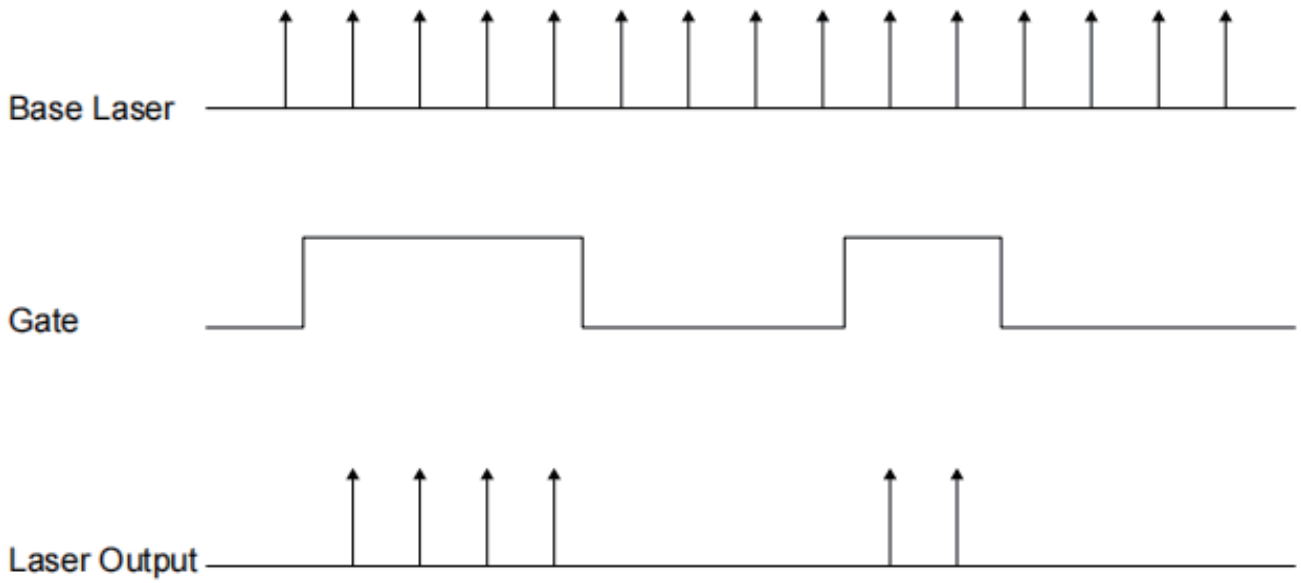

* Gate Timing Diagram

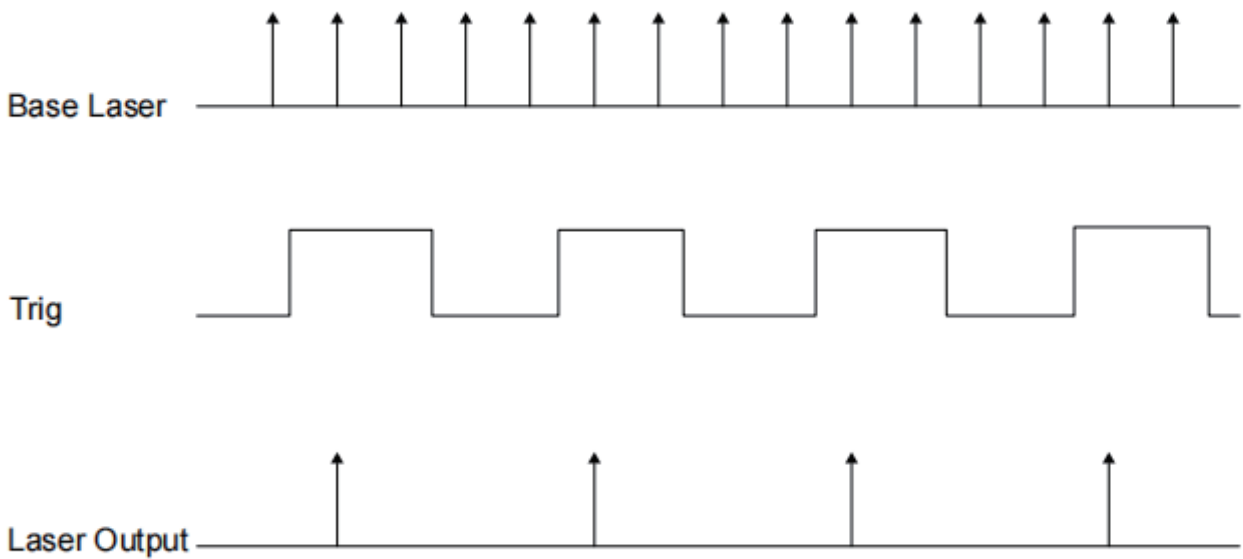

* Trigger Timing Diagram

Signal connection between laser and control card

1. All-in-one machine signal connection

激光器控制接口

金橙子打标板卡DB15接口

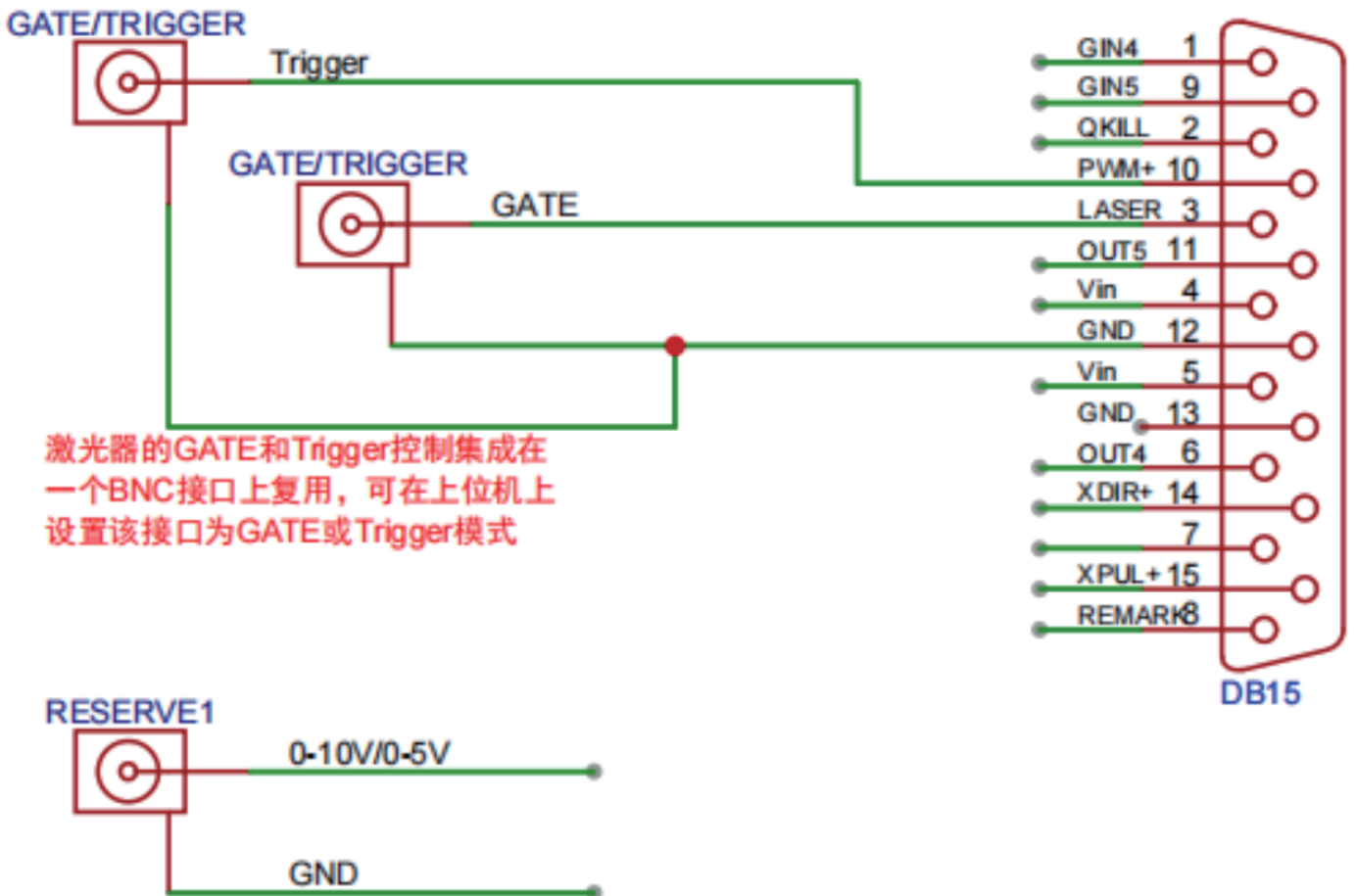

激光器的GATE和Trigger控制集成在一个BNC接口上复用，可在上位机上设置该接口为GATE或Trigger模式

激光器的RESERVE1为模拟量功率调节接口，可在上位机上设置功率调节方式为内控/外部0-10V/外部0-5V，使用外部功率调节需要机台控制板卡支持此功能

*Example 1

金椰子打标板卡DB25接口

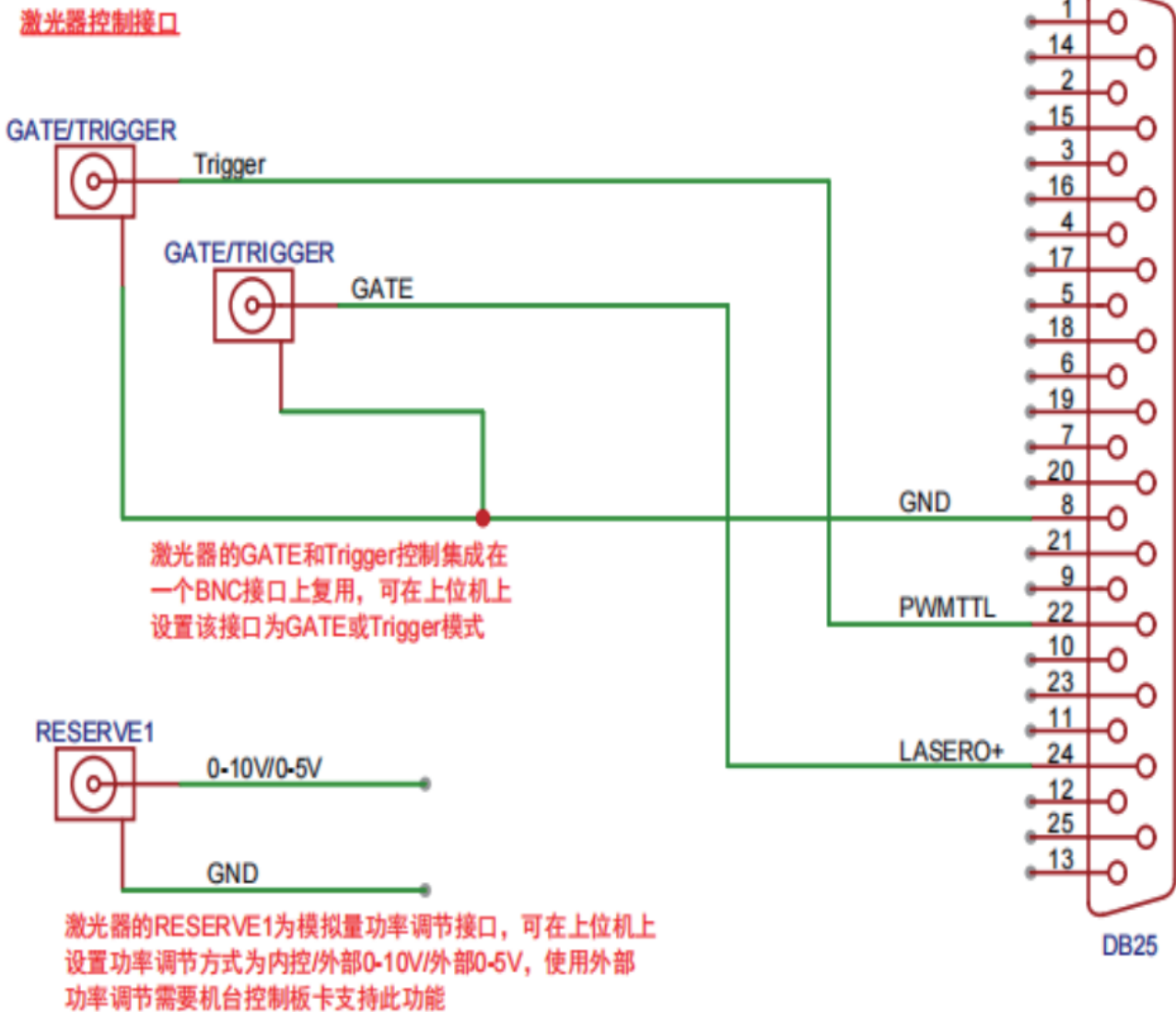

*Example 2

2 Signal Connection for Split-type Machine

The GATE and TRIGGER of the modular machine are two independent BNC interfaces; when the upper stand selects processing mode as GATE or TRIGGER mode, the connected hardware interface must be consistent with the upper computer.

Simple Operation Instructions for Host Computer Software

1. The software program is stored on a random box U disk (the software has been developed with two versions: standard and simplified for customer needs; if the customer does not specify a version, please use the version included with the shipment. Software versions are updated irregularly; it is recommended to contact sales personnel for the latest version);

2. Due to incomplete system drivers and runtime libraries, some PCs cannot open software and display information such as C++ runtime; it is recommended to update the system's C++ runtime library;

3. Use the built-in serial port cable to connect the laser and PC;

4. Double-click the software icon or right-click to run the application as administrator, then enter the following connection interface.



(1) By default, only the “E-STOP” and “INTERLOCK” functions are enabled. The other functions described above are customized for some customers. If you need to enable these functions or customize other functions, please confirm with our sales staff in advance!

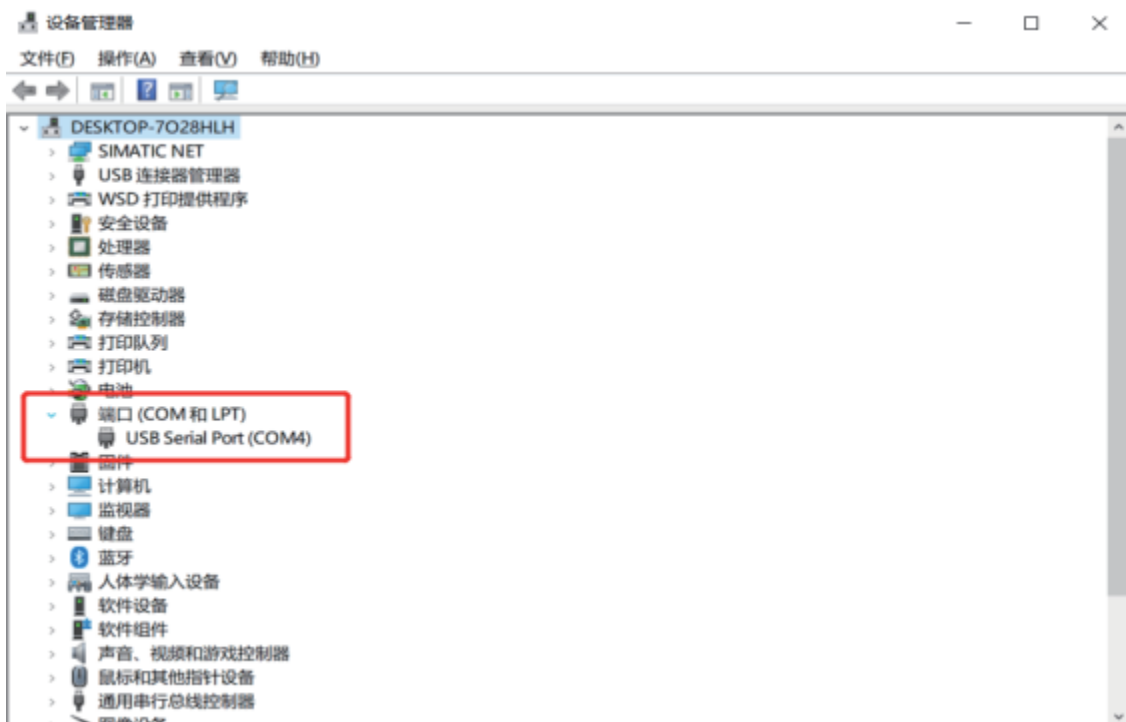

(2) Select the correct port number, connect the laser, and enter the user interface

Standard Edition Software

星创激光器控制系统--H25UTP0004001

用户界面 | 日志 | 帮助

操作区域

频率 [kHz] 80 | Burst 1 | AOM2功率 0 mW | 激光器开关 0%

功率 内部百分比 50 | 频率 (kHz) 80 | 控制模式 待机 | Shutter OFF

倍频控制

SHG (°C) 45 | THG (°C) 45

校正系数 1

状态及倍频

主控器通讯	传感器通讯	功能模块通讯	水流量 (L/min) 0	水温 (°C) ----	水压 (MPa) ----
功能模块状态	急停状态	Interlock	AMP1 (°C) 22.9	AMP2 (°C) 23.8	AMP3 (°C) 23
AOM2待机模式	X1	除湿泵	AMP4 (°C) 24	AMP5 (°C) 25	SSP (°C) 23.1
AOM2 Trigger模式	X2	AOM2 Shutter	TMU1 (°C) 23.5	TMU2 (°C) 23.2	TMU3 (°C) 21.3
AOM2 Gate模式	X3	Y2	HMU1 (%RH) 83.9	HMU2 (%RH) 72.9	HMU3 (%RH) 42.6
AOM2内控模式	Y1	Y3			

基本信息

P/N 341835776 | S/N H25UTP0004001 | 机器型号 | 推荐水温 (°C) 23

固件版本 1.4.14 | 硬件版本 2.2.1 | 软件版本 1.8.70 | 推荐水流量 (L/min) 6

设置功率校正系数为1 (完成)
通信已连接 (COM14-9600)

异常 告警代码: 10501 腔内湿度异常触发急停 告警代码: 97

Note: The updated version of the upper computer has added new functions for power regulation, including "internalpercentage adjustment", "external o-1oV", and "external 0-SV". These correspond to the RESERVE interface on the abovesplit unit and the RESERVE1 interface on the integrated-unit.

The figure below shows the dual-laser head version; only AOM2 is operable for single-head laser.

星创激光器控制系统--H25UTPD004001

用户界面 | 日志 | 帮助

操作区域

频率 (kHz) 80 | 0 | 确定 | HMI急停 ON | 除湿 OFF

Burst 1 | 1 | 确定

AOM1

功率 内部百分比 0 | 0% | 确定 | 控制模式 待机 | Shutter OFF

频率 (kHz) 0 | 0 | 确定

AOM2

功率 内部百分比 50 | 50% | 确定 | 控制模式 待机 | Shutter OFF

频率 (kHz) 80 | 80 | 确定

激光器开关 0%

AOM1功率 0 mW

AOM2功率 0 mW

校正系数 1 | 确定

倍频控制

SHG (°C) 45 | 25.1 | 确定

THG (°C) 45 | 25.5 | 确定 | 恢复默认

状态及倍频

<input checked="" type="checkbox"/> 主控制器通讯	<input checked="" type="checkbox"/> 传感器通讯	<input type="checkbox"/> 功能模块通讯	水流量 (L/min) 0	水温 (°C) ----	水压 (MPa) ----
<input checked="" type="checkbox"/> 功能模块状态	<input type="checkbox"/> 急停状态	<input type="checkbox"/> Interlock	AMP1 (°C) 22.7	AMP2 (°C) 23.9	AMP3 (°C) 23
<input checked="" type="checkbox"/> AOM1待机模式	<input checked="" type="checkbox"/> AOM2待机模式	<input type="checkbox"/> 除湿泵	AMP4 (°C) 24	AMP5 (°C) 25	SSP (°C) 23.1
<input type="checkbox"/> AOM1 Trigger模式	<input type="checkbox"/> AOM2 Trigger模式	<input type="checkbox"/> AOM1 Shutter	TMU1 (°C) 23.5	TMU2 (°C) 23.2	TMU3 (°C) 21.3
<input type="checkbox"/> AOM1 Gate模式	<input type="checkbox"/> AOM2 Gate模式	<input type="checkbox"/> AOM2 Shutter	HMU1 (%RH) 83.8	HMU2 (%RH) 72.9	HMU3 (%RH) 42.6
<input type="checkbox"/> AOM1内控模式	<input type="checkbox"/> AOM2内控模式				

基本信息

P/N 341835776 | S/N H25UTPD004001 | 机器型号 | 推荐水温 (°C) 23

固件版本 1.4.14 | 硬件版本 2.2.1 | 软件版本 1.8.70 | 推荐水流量 (L/min) 6

Operation Area: Mainly for setting and operating the laser device

操作区域

频率 (kHz) 80 | 0 | 确定 | HMI急停 ON | 除湿 OFF

Burst 1 | 1 | 确定

AOM2

功率 内部百分比 50 | 50% | 确定 | 控制模式 待机 | Shutter OFF

频率 (kHz) 80 | 80 | 确定

激光器开关 0%

AOM2功率 0 mW

校正系数 1 | 确定

倍频控制

SHG (°C) 45 | 25.1 | 确定

THG (°C) 45 | 25.5 | 确定 | 恢复默认

Status Feedback Area: Mainly includes feedback data on laser unit status and sensor information

状态及倍频

<input checked="" type="checkbox"/> 主控制器通讯	<input checked="" type="checkbox"/> 传感器通讯	<input type="checkbox"/> 功能模块通讯	水流量 (L/min) 0	水温 (°C) ----	水压 (MPa) ----
<input checked="" type="checkbox"/> 功能模块状态	<input type="checkbox"/> 急停状态	<input type="checkbox"/> Interlock	AMP1 (°C) 22.8	AMP2 (°C) 24.2	AMP3 (°C) 23
<input checked="" type="checkbox"/> AOM2待机模式	<input checked="" type="checkbox"/> X1	<input type="checkbox"/> 除湿泵	AMP4 (°C) 24	AMP5 (°C) 25	SSP (°C) 23.1
<input type="checkbox"/> AOM2 Trigger模式	<input type="checkbox"/> X2	<input type="checkbox"/> AOM2 Shutter	TMU1 (°C) 23.5	TMU2 (°C) 23.3	TMU3 (°C) 21.3
<input type="checkbox"/> AOM2 Gate模式	<input type="checkbox"/> X3	<input type="checkbox"/> Y2	HMU1 (%RH) 84.1	HMU2 (%RH) 73.1	HMU3 (%RH) 42.6
<input type="checkbox"/> AOM2内控模式	<input type="checkbox"/> Y1	<input type="checkbox"/> Y3			

Basic Information Area: Mainly includes laser SN and version information

基本信息							
P/N	341835776	S/N	H25UTPA004001	机器型号		推荐水温 (°C)	23
固件版本	1.4.14	硬件版本	2.2.1	软件版本	1.8.70	推荐水流量 (L/min)	6

Information Prompt Area: Primarily used for operation prompts, alarms, and prompt messages

通信已连接(COM14-9600) | 告警代码: 9733 腔内湿度异常 | 告警代码: 10501 腔内湿度异常

(3) Select laser repetition rate, Burst and set parameters

频率 (kHz)	80	0	确定
Burst	1	1	

(4) Click the upper computer laser switch button

If the laser does not meet the activation conditions, the upper machine will pop up a prompt please troubleshoot based on actual conditions. After troubleshooting, click the upper machine's laser switch button again to activate the laser.

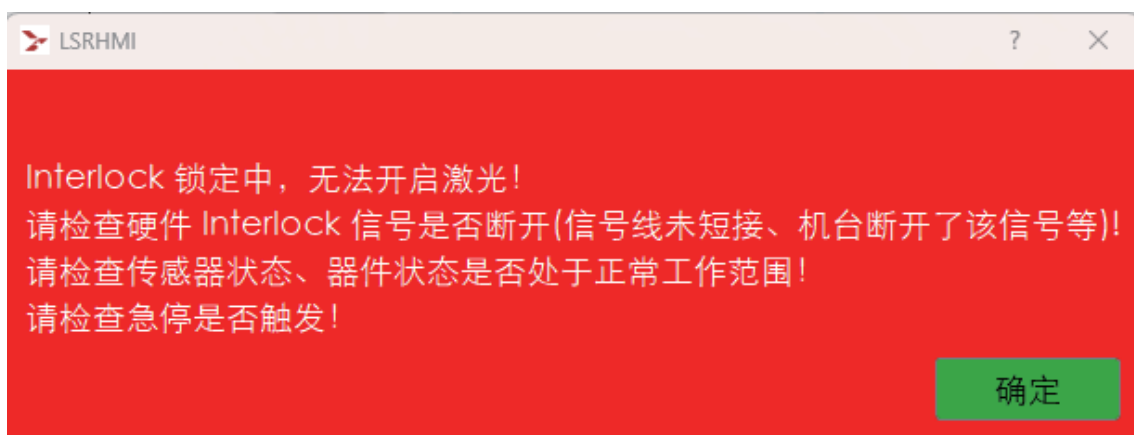

(5) Wait for the laser to be turned on; the progress bar will display the current activation progress

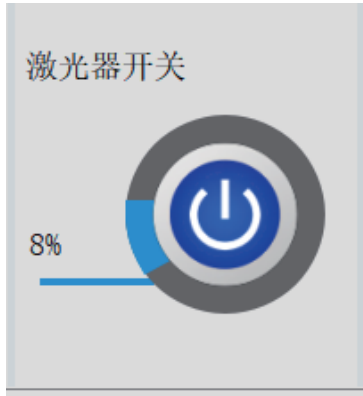

* Starting up



* After the laser is switched on

(6) Select AOM control mode

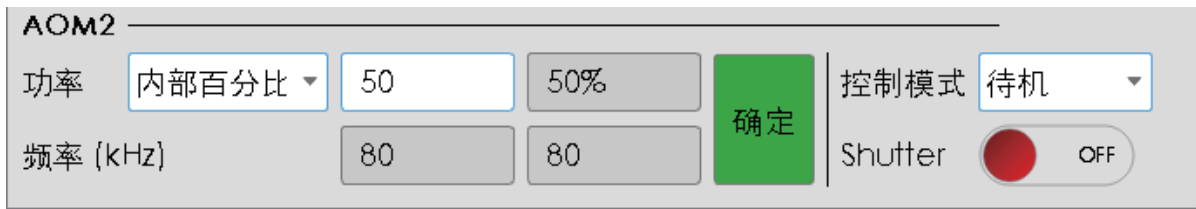

When selecting Gate mode, you can set the AOM frequency (dividing). The divided frequency must be less than the set laser frequency.

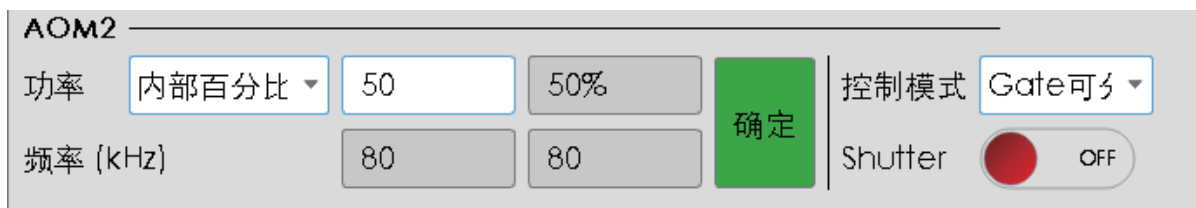

When selecting any Tigger mode, you can set force processing parameters (processing speed, point spacing, compensation number,

Update the recommended machining speed; it is recommended to use the suggested machining speed for processing.

操作区域

频率 (kHz) 80 0 确定

Burst 1 1 确定

HMI急停 ON

除湿 OFF 加工参数

AOM2

功率 内部百分比 50 50% 确定

控制模式 Trigger普

频率 (kHz) 80 80 确定

Shutter OFF

加工参数设置

加工速度 (mm/s) 100

建议加工速度 (mm/s) 80 更新

点间距 (um) 5

补偿数 50

确定

(7) Update the recommended machining speed; it is recommended to use the suggested machining speed for processing.

AOM2

功率 内部百分比 50 50% 确定

控制模式 Trigger普

频率 (kHz) 80 80 确定

Shutter ON

(8) Turn off laser

In the state where the laser is turned on, click the upper computer laser switch button to turn off the laser, and the progress bar will display the current closing progress (in reverse order).

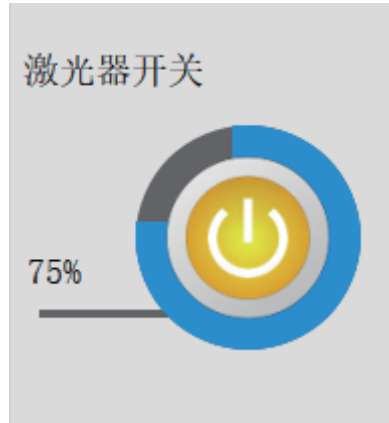

(9) Frequency Doubling Control Description



The left side shows the set temperature, and the right side shows the current temperature. The background color is orange when heating, and blue when cooling.

*** The multi-frequency temperature has been optimized before the laser leaves the factory, so do not change it at will.**

(10) Log Query

Alarm Record Inquiry: Can query current and historical alarm records

*Emergency alert.

序号	告警代码	报警级别	告警信息	告警触发时间
1	10499	故障	泵源温度异常触发急停	2023-08-30 13:34:00
2	9733	警告	腔内湿度异常	2023-08-30 13:34:00
3	9740	警告	2#温度传感器开路故障	2023-08-30 13:34:00
4	9742	警告	3#温度传感器开路故障	2023-08-30 13:34:00
5	9744	警告	4#温度传感器开路故障	2023-08-30 13:34:00

打开AOM2 Shutter开关 | 报警代码: 10499 泵源温度异常触发急停 报警代码: 9733 腔内湿度异常 报警代码: 9740 2#温度传感器开路故障

* Current Alarm:

序号	告警代码	报警级别	告警信息	告警触发时间	告警解除时间
1	8961	警告	SHG-TEC低温报警	2023-05-23 10:59:09	2023-05-24 09:46:11
2	8977	警告	T\FHG-TEC低温报警	2023-05-23 10:59:09	2023-05-24 09:46:11
3	8961	警告	SHG-TEC低温报警	2023-05-23 14:22:00	2023-05-24 09:46:11
4	8977	警告	T\FHG-TEC低温报警	2023-05-23 14:22:00	2023-05-24 09:46:11
5	9216	警告	下位机不支持当前HMI版本	2023-05-23 14:22:35	2023-05-23 14:23:11
6	8961	警告	SHG-TEC低温报警	2023-05-23 14:23:11	2023-05-24 09:46:11
7	8977	警告	T\FHG-TEC低温报警	2023-05-23 14:23:11	2023-05-24 09:46:11
8	10499	故障	泵源温度异常触发急停	2023-05-23 14:27:21	2023-05-23 14:27:35
9	8961	警告	SHG-TEC低温报警	2023-05-23 16:38:29	2023-05-24 09:46:11
10	8977	警告	T\FHG-TEC低温报警	2023-05-23 16:38:29	2023-05-24 09:46:11
11	10497	故障	HMI软件急停被触发	2023-05-23 16:40:18	2023-05-23 16:40:21
12	10496	故障	硬件急停被触发	2023-05-24 09:46:11	2023-05-24 15:46:42
13	10496	故障	硬件急停被触发	2023-05-24 09:59:15	2023-05-24 15:46:42
14	10496	故障	硬件急停被触发	2023-05-24 10:09:24	2023-05-24 15:46:42
15	9216	警告	下位机不支持当前HMI版本	2023-05-24 11:10:47	2023-05-24 11:11:44
16	10496	故障	硬件急停被触发	2023-05-24 11:11:44	2023-05-24 15:46:42

打开AOM2 Shutter开关 | 报警代码: 10499 泵源温度异常触发急停 报警代码: 9733 腔内湿度异常 报警代码: 9740 2#温度传感器开路故障 报警代码: 9742 3#温度传感器开路故障

* **Current Alarm:**



The screenshot shows the 'Star Laser Control System' (星光激光器控制系统) interface. The top navigation bar includes '用户界面', '日志', and '帮助'. Below this, there are buttons for '报警日志', '操作日志', and '运行日志'. The main content area displays a table of operation logs with columns for '序号' (Serial Number), '操作信息' (Operation Information), and '操作时间' (Operation Time). At the bottom, there is a status bar with a '刷新' (Refresh) button and several alarm messages.

序号	操作信息	操作时间
1	打开AOM2 Shutter开关	2023-08-30 13:56:34
2	设置功率为50%	2023-08-30 13:55:29
3	设置AOM2频率为50kHz	2023-08-30 13:55:29
4	设置加工速度为100mm/s	2023-08-30 13:53:38
5	设置点间距为5um	2023-08-30 13:53:38
6	设置加工速度为100mm/s	2023-08-30 13:53:34
7	设置点间距为5um	2023-08-30 13:53:34
8	设置补偿数为50	2023-08-30 13:53:34
9	设置AOM2控制模式为Trigger普通	2023-08-30 13:52:25
10	设置功率为0%	2023-08-30 13:52:19
11	设置AOM2频率为50kHz	2023-08-30 13:52:19
12	设置AOM2控制模式为Gate	2023-08-30 13:51:23
13	设置AOM2控制模式为待机	2023-08-30 13:50:31
14	设置AOM2控制模式为Trigger普通	2023-08-30 13:50:14
15	设置AOM2控制模式为待机	2023-08-30 13:49:06
16	设置AOM2控制模式为内控	2023-08-30 13:49:02
17	设置AOM2控制模式为Gate	2023-08-30 13:48:52
18	设置AOM2控制模式为待机	2023-08-30 13:48:50

报警信息: 打开AOM2 Shutter开关

报警信息: 0499 泵源温度异常触发急停 告警代码: 9733 腔内湿度异常 告警代码: 9740 2#温度传感器开路故障 告警代码: 9742 3#

* **Operation Log: Currently, partial operation time records can be queried**

A simple version of the software



The relevant operational logic is consistent with the regular version

Select the corresponding COM port number to enter the interface;

Check interlock and emergency stop indicators, check alarm information prompts, contact our company if there is any fault;

It is recommended to set the laser power to 1% and switch the light gate switch to OFF before irradiation;

Set the seed source frequency, Burst; please follow the factory report settings for allowable range and click OK;

One-click start the laser, wait for the laser progress to reach 100%;

Select the processing mode as internal control, and switch the light gate to ON under safe conditions;

The laser starts emitting light, check the spot at the emission port;

After debugging the optical path, select the processing mode GATE/TRIGGER as needed.

Common Fault Table

For any unlisted faults, please contact our after-sales service personnel or our customer service hotline (Tel: 0551-65652939)

FaultCode	Fault Name	Possible Cause /Solution Method
None	Interrupted downstream communications	<p>Possible Causes: PC and electrical control box connection interrupted or data parsing error</p> <p>Solution: 1. Check if the connection cable and COM port are correct; 2.</p>
9216	Update Host Computer Version HMI version	<p>Update Host Computer Version</p> <p>Possible Causes: The top-level version is not supported</p> <p>Solution: 1. Restart the secondary machine 2. Update the upper computer version</p>
10496	Hardware emergency stop triggered	<p>Possible Causes: The emergency switch is pressed or the external emergency signal is disconnected</p> <p>Solution: 1. Emergency stop switch has returned to normal state</p>
10497	HMI software emergency stop triggered	<p>Possible Causes: HMI software emergency stop is enabled</p> <p>Solution: 1. Close HMI software emergency stop</p>

9730/10498	Abnormal seed source temperature triggers a pause	<p>Possible Causes: Seed source temperature abnormal or sensor failure</p> <p>Solution: 1. Check the temperature value feedback from the software interface and contact after-sales personnel</p>
9731/10499	An abnormal temperature of the pump source triggers an emergency stop	<p>Possible Causes: Pump source temperature abnormal or sensor failure</p> <p>Solution: 1. Check the temperature value feedback from the software interface and contact after-sales personnel</p>
9734/10502	Abnormal water flow triggers emergency stop	<p>Possible Causes: Abnormal water flow or sensor failure</p> <p>Solution: 1. Check if the water flow rate of the water-cooled machine is normal; 2. Check connections between the inlet and outlet pipes; Check whether the water pipes are properly connected and whether there are any reverse connections; 3. Check the temperature value feedback from the software interface and contact after-sales personnel</p>
9736 - 9752	Monitoring system abnormal, sensor Device data is unreliable	<p>Possible Causes: Sensor Failure</p> <p>Solution: 1. Check the data feedback from the software interface and contact after-sales personnel.</p>