

StarLight Series Femtosecond Laser Operation Manual

Femtosecond Laser Operation Guide

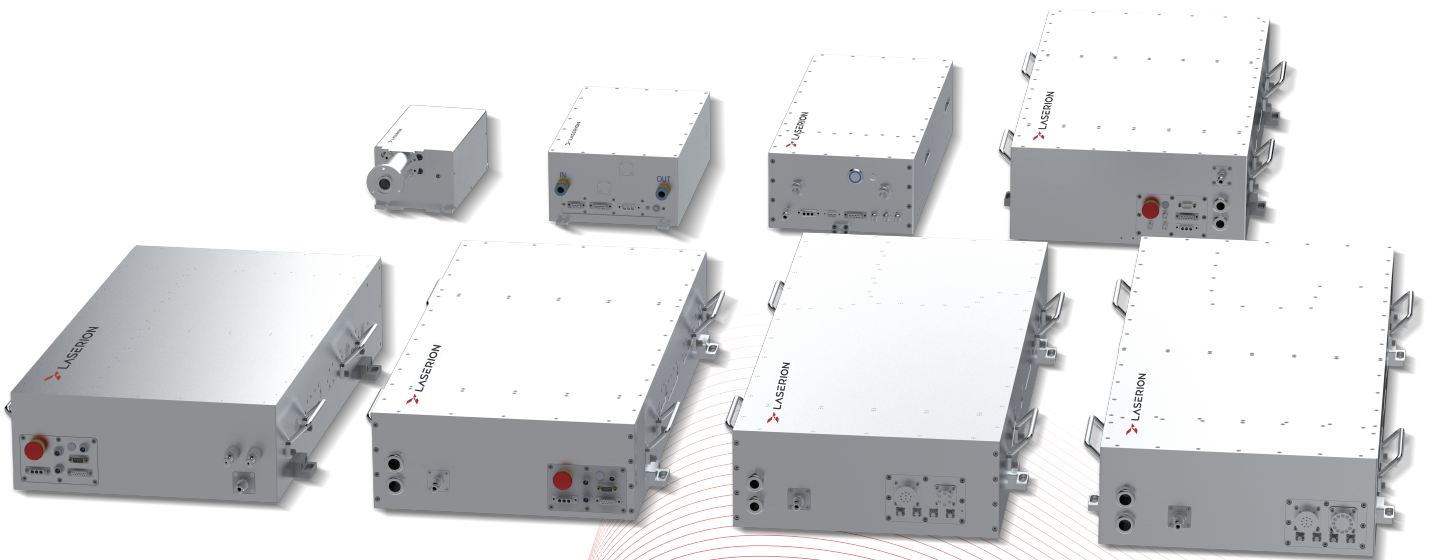

Table of Contents

1.Safety Precautions	3
2.Power Connection	3
3.Equipment Composition	3
3.1 Split-type System	3
3.2 Integrated System	4
4.System Signal Connection	6
5.External Signal Description	9
5.1 Split-type System	9
5.2 Integrated System	10
5.3 Important I/O Interface Definition	11
6.Startup Procedure	12
7.Operating Modes	13
8.Laser Signal Connection with Control Card	15
8.1 Integrated System Signal Connection	15
8.2 Split-type System Signal Connection	16
9.Host Software Operation	16
10.Fault Codes & Troubleshooting	27

1. Safety Precautions SAFETY PRECAUTIONS

- * Select the appropriate power supply according to the Detailed Specification Sheet.
 - * Check the working environment and peripheral configuration according to the General Safety Instructions.
 - * Do not squeeze or excessively bend external water pipes and cables.
- Never look directly into the laser output aperture during operation. Wear certified laser safety goggles.
- * Disconnect all power before wiring or maintenance.

2. Power Connection POWER CONNECTION

- * Power supply: Single-phase 220V AC.
- * Connect Live, Neutral, and Ground wires correctly as labeled. Poor grounding may cause potential damage.
- * A circuit breaker (air switch) and voltage stabilizer are strongly recommended between the power supply unit and the laser power socket.

3. Equipment Composition EQUIPMENT COMPOSITION

The laser system is available in **split-type** and **integrated** structures.

3.1 Split-type System

- * Laser unit
- * Electric control cabinet
- * Water chiller

* Split-type System



* Front Panel of Laser Equipment

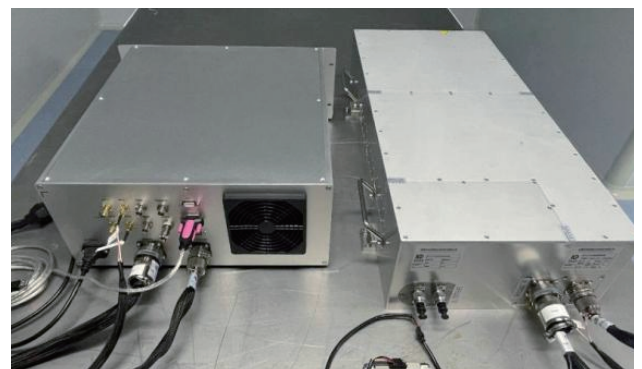

* Rear Panel of Laser Equipment



* Front Panel of Electric Control Cabinet



* Rear Panel Interfaces of Electric Control Cabinet



* Front Panel of Laser Head



* Rear Panel Interfaces of Laser Head

3.2 Integrated System

- * Laser unit
- * Power Supply
- * Water chiller

* Integrated System



* Front Panel of Laser Equipment

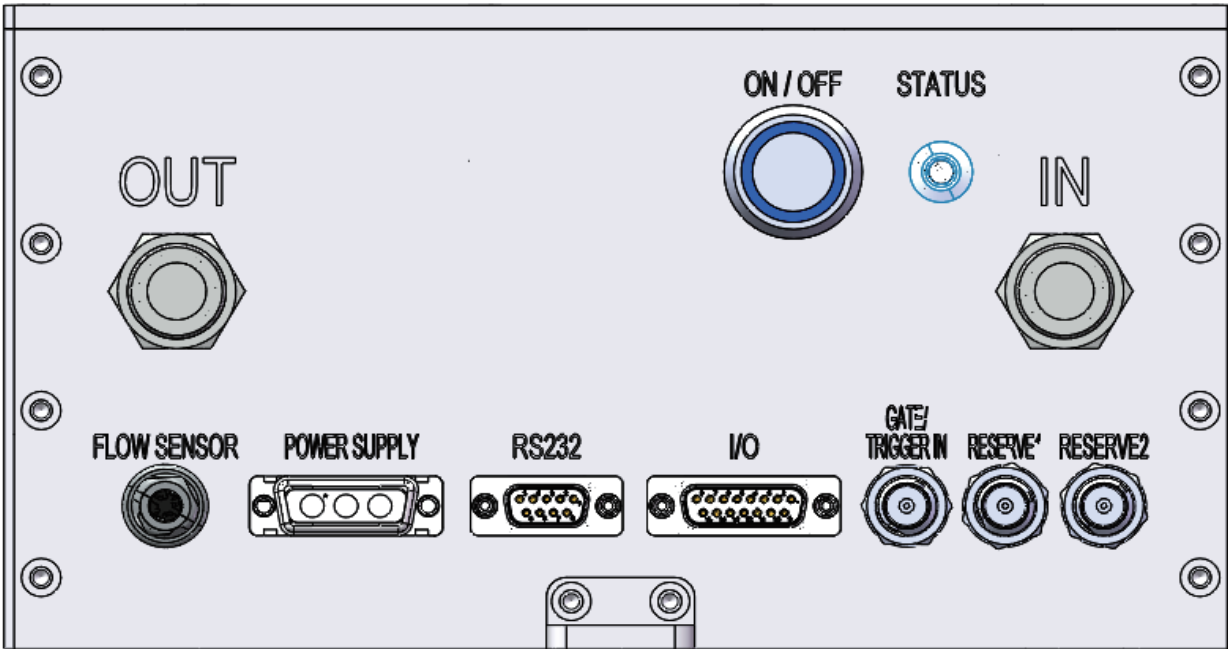

* Front Panel One

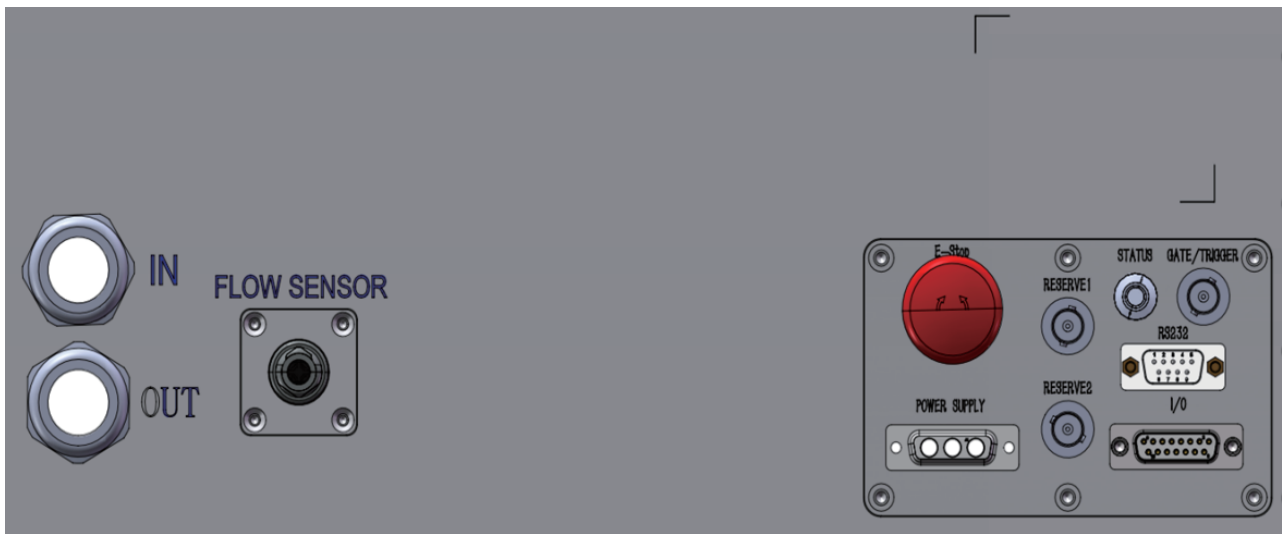

* Front Panel Two

4. System Signal Connection

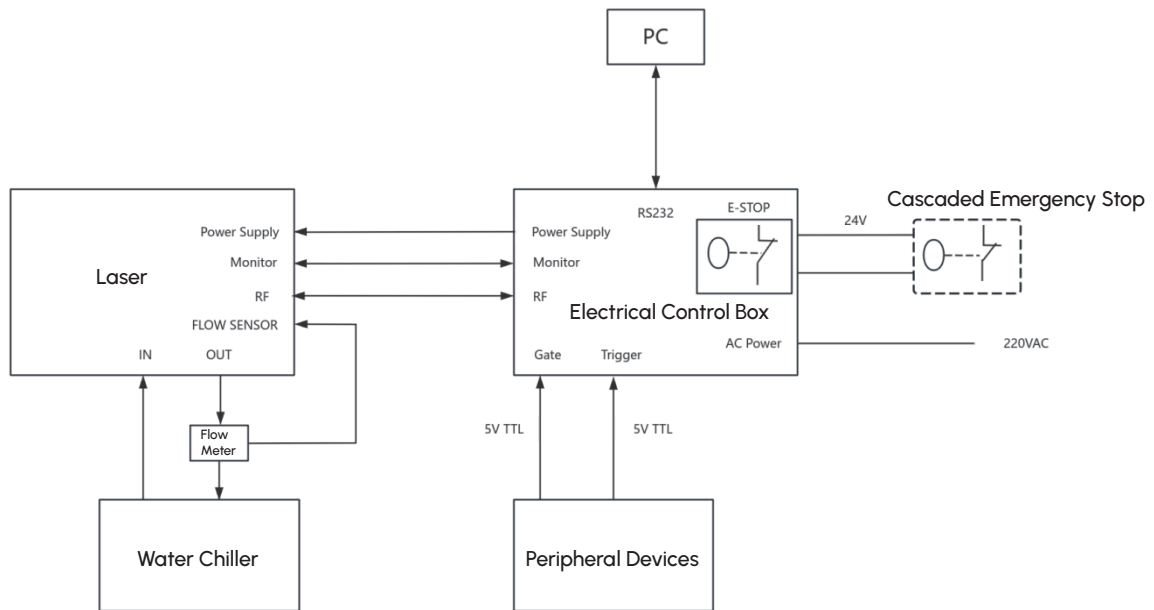

*Split-type Connection

- a. Connect 55-pin, 6-pin / 12-pin connectors between the laser and control cabinet. Connect RF cables according to RF labels.
- b. Connect the flow sensor plug to the FLOW SENSOR interface. Ensure the arrow direction matches the water flow direction. (The flowmeter is enabled by default and two pieces are delivered as wearing parts. If shielding of the flowmeter function is required, please confirm with sales personnel in advance. When connecting to the water chiller, ensure the arrow direction of the flowmeter is consistent with the water flow direction.)
- c. For models without a dedicated flowmeter interface, connect the flowmeter to the 3-pin connector led out from the 55-pin aviation plug. For this version of laser, please refer to the labels on the 55-pin aviation plug to distinguish between the laser-end and electric-control-cabinet-end directions!
- d. Keep the E-STOP interface short-circuited.
- e. For lasers with I/O functions, a DB9 male connector with short-circuited INTERLOCK is delivered with the product. Check whether the DB9 male connector is plugged into the I/O port of the electric control cabinet. For usage instructions, refer to the I/O Interface section below.
- f. Connect the RS232 communication cable.
- g. Connect GATE or TRIGGER signals from the processing machine as required.

* Brief Description of External Signals

AC POWER: Laser power input, externally connected to 220V AC. A 250V AC 10A fuse is pre-installed inside the electric control cabinet. It is strongly recommended to connect a circuit breaker (air switch) and a voltage stabilizer in series between the power supply unit and the laser power socket for convenient wiring operation.

GATE: Externally connected to the GATE signal of processing equipment, 5V TTL level.

TRIGGER: Externally connected to trigger signals such as TRIGGER/PSO/POD of processing equipment, 5V TTL level. The input signal frequency shall be lower than the set laser repetition frequency.

RESERVE: This is a reserved interface for external power adjustment, supporting 0-10V or 0-5V input. Please contact our company for confirmation if this function is required.

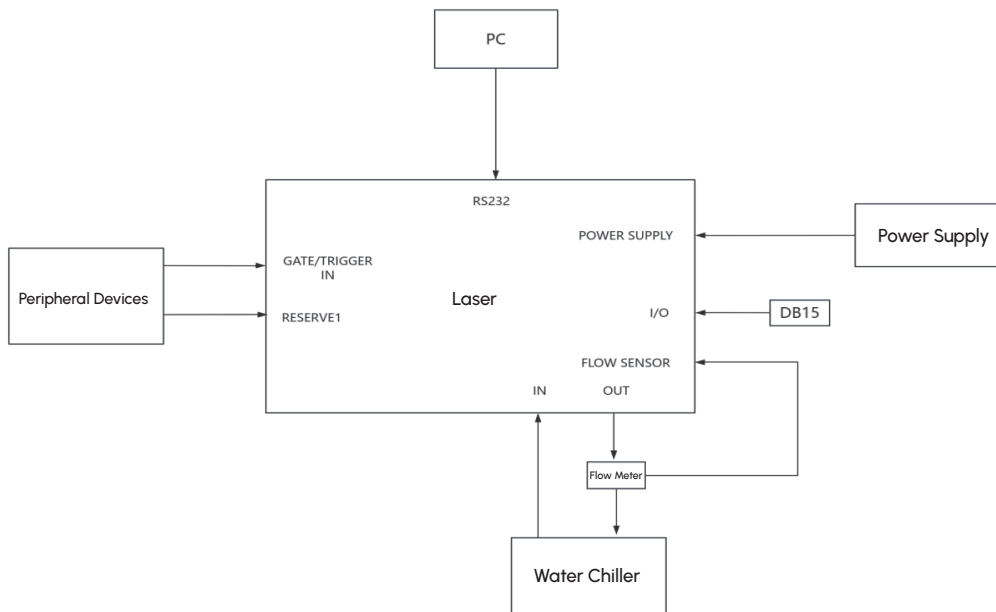

*Integrated Connection

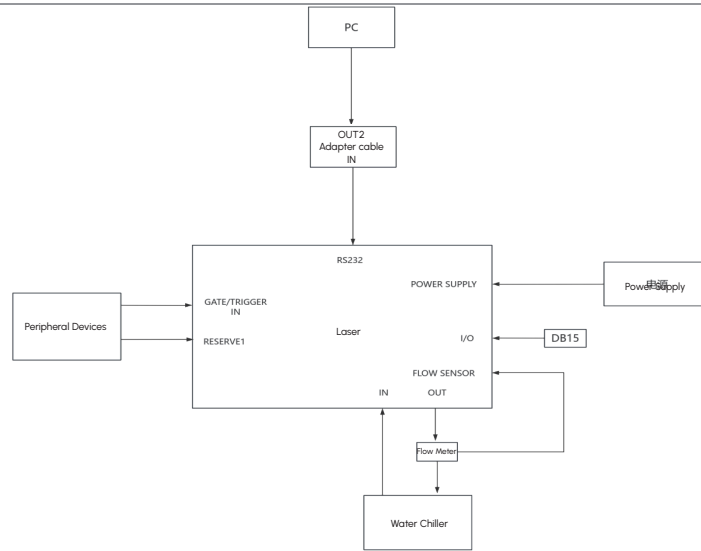

*Connection diagram for a single-unit system (femtosecond model)

h. Connect the input terminal of the switching power supply to 220VAC, and connect the output terminal to the laser POWER SUPPLY. The output cables are labeled V+, V-, and GND. To ensure good grounding of the laser, a ground wire is reserved at the power output terminal; it is recommended to extend it for direct grounding.

i. Plug the flowmeter connector into the FLOW SENSOR interface. (The flowmeter is enabled by default, and two pieces are delivered as wearing parts. If shielding of the flowmeter function is required, please confirm with sales personnel in advance. When connecting to the water chiller, ensure the arrow direction of the flowmeter is consistent with the water flow direction.)

j. Insert the delivered DB15 male connector, with cascaded emergency stop and INTERLOCK short-circuited by default. For usage instructions, refer to the I/O Interface section below.

k. Plug the communication cable into the RS232 interface to operate the control software.

* Brief Description of External Signals

STATUS: When the status indicator flashes yellow, the laser is ready for emission; flashing green indicates laser-on or laser-off process, steady green means laser is emitting; steady or flashing red denotes a fault. Please check the fault cause via the host software or contact our after-sales service.

GATE/TRIGGER: Externally connected to signals from processing equipment. The Gate signal is 5V TTL level; TRIGGER connects trigger signals such as TRIGGER/PSO/POD from processing equipment (5V TTL level), and the input signal frequency must be lower than the set laser repetition frequency. Switch the processing mode via the host software.

RESERVE1: This is a reserved interface for external power adjustment, supporting 0-10V or 0-5V input. Please confirm with sales personnel in advance if this function is required.

5.External Signal Description EXTERNAL SIGNAL DESCRIPTION

The laser I/O interface is a high-quality, easy-to-wire DB9 (split-type unit) / DB15 (integrated unit) interface, which provides multiple signals for functional control of the laser. The detailed description is as follows:

5.1 Split-type System

DB9 Pin	Signal ID	Description
1	0V	Signal common ground. Do not connect to any non-0V (GND) pins.
2	Laser Alarm Status Indicator	5V NPN signal output (0V). Used to indicate whether the laser has an alarm. pins.
3	Laser Emission Status Indicator	5V NPN signal output (0V). Used to indicate whether the laser has been emitted (turned on).
4	Motion Enable Status Indicator	5V NPN signal output (0V). Used to indicate whether the laser is stable and the processing equipment can start moving and processing.
5	Interlock 1	Dry contact. Short with Interlock 2 when not in use; the laser will be locked if not shorted. Do not connect to other pins.
6	5V	Used for signal power supply. Do not connect to any 0V/GND/PE pins.
7	Shutter Enable	5V PNP signal input (5V). Used to turn on/off the shutter.
8	Laser Enable	5V PNP signal input (5V). Used to turn on/off the laser.
9	Interlock 2	Dry contact. Short with Interlock 1 when not in use; the laser will be locked if not shorted. Do not connect to other pins.

5.2 Integrated System

DB15 Pin	Signal ID	Description
1	Interlock 1	Dry contact. Short with Interlock 2 when not in use; the laser will be locked if not shorted. Do not connect to other pins.
2	E-STOP 1	Dry contact. Short with E-STOP 2 when not in use; the laser emergency stop will be triggered if not shorted. Do not connect to other pins.
3	INTERLOCK Status Indicator	5V NPN signal output (0V). Used to indicate the internal INTERLOCK status.
4	Motion Enable Status Indicator	5V NPN signal output (0V). Used to indicate whether the laser is stable and the processing equipment can start moving and processing.
5	Laser Emission Status Indicator	5V NPN signal output (0V). Used to indicate whether the laser has been emitted (turned on).
6	Laser Alarm Status Indicator	5V NPN signal output (0V). Used to indicate whether the laser has an alarm.
7	5V	Used for signal power supply. Do not connect to any 0V (GND)/PE pins.
8	5V	Used for signal power supply. Do not connect to any 0V (GND)/PE pins.
9	Interlock 2	Dry contact. Short with Interlock 1 when not in use; the laser will be locked if not shorted. Do not connect to other pins.
10	E-STOP 2	Dry contact. Short with E-STOP 1 when not in use; the laser emergency stop will be triggered if not shorted. Do not connect to other pins.
11	Spare Input	5V PNP signal input (5V).
12	Laser Enable	5V PNP signal input (5V). Used to turn on/off the laser.
13	Shutter Enable	5V PNP signal input (5V). Used to turn on/off the shutter.
14	0V	Signal common ground. Do not connect to any non-0V/GND pins.
15	0V	Signal common ground. Do not connect to any non-0V/GND pins.

5.3 Important I/O Interface Definition

E-STOP: This interface allows users to connect additional cascaded emergency-stop switches. The laser operates normally when the circuit is closed, and emergency stop is triggered to stop laser emission when the circuit is open.

INTERLOCK: Laser emission is allowed when short-circuited; the laser is locked and emission prohibited when open. Note that the laser can be turned off when INTERLOCK is open, but cannot be turned on again.

Motion Enable Status Indicator: This pin works with Pin 6 (split-type unit) or Pin 7/8 (integrated unit). When the laser emits normally, 5V and 0V form a circuit with the action switch of external processing equipment. The signal disappears when emission stops, which can be used by processing equipment to link motion and stop functions.

Laser Enable: This pin works with Pin 6 (split-type unit) or Pin 7/8 (integrated unit). A switching device is connected between 5V and this pin; the laser turns on under fault-free conditions when 5V is connected to this pin.

Shutter Enable: This pin works with Pin 6 (split-type unit) or Pin 7/8 (integrated unit). A switching device is connected between 5V and this pin; the shutter opens to release laser when 5V is connected to this pin (only available for lasers with built-in shutter structure).

Only E-STOP and INTERLOCK are enabled by default. Other above-mentioned functions are customer-specific customizations. Please confirm with our sales personnel in advance if these functions or other custom functions are required.

6.Startup Procedure STARTUP PROCEDURE

WARNING:

- *Ensure all electrical connections (including water pipes) are properly connected before use. Where applicable, all connectors must be tightened and fixed with screws.
- *Do not look directly into the laser output aperture during operation; always wear certified laser-safety goggles.
- *Turn off all power switches of the laser before performing any wiring operations.

Startup / Shutdown Procedure is as follows:

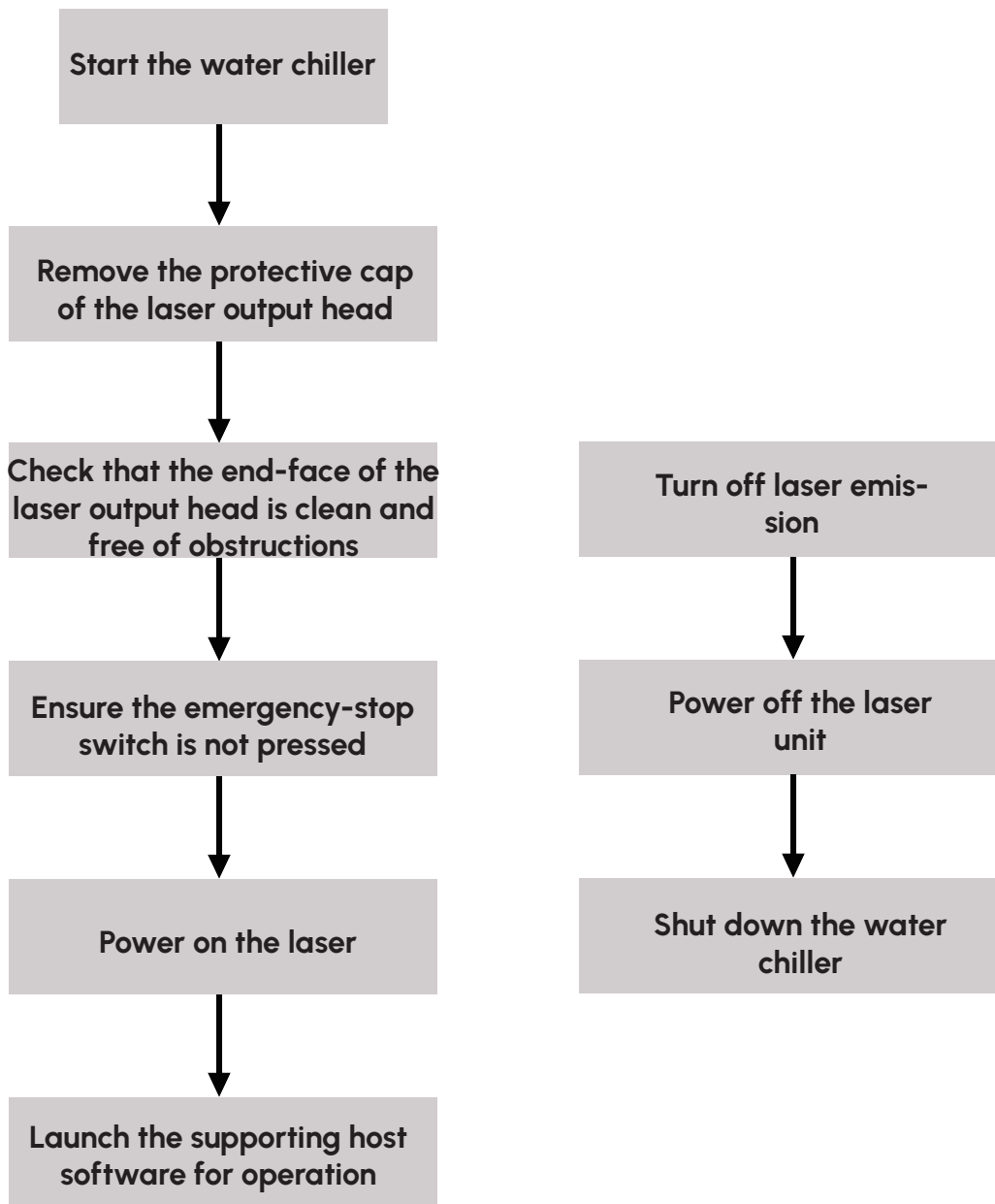

7. Operating Modes OPERATING MODES

- a. **Standby Mode:** AOM standby, output signal disabled.
- b. **Internal Control Mode:** The AOM outputs control signals according to internal signals to regulate laser emission.
- c. **Gate Mode:** When the Gate signal is high-level, the AOM outputs control signals according to internal signals to regulate laser emission.
- d. **Normal Trigger Mode:** Upon the rising edge of the Trigger signal, the AOM outputs control signals according to internal signals to regulate laser emission.
- e. **Average Trigger Mode:** Upon the rising edge of the Trigger signal, the AOM outputs control signals according to internal signals to regulate laser emission.
- f. **Compensated Trigger Mode:** Upon the rising edge of the Trigger signal, the AOM outputs control signals according to internal signals to regulate laser emission.
- g. **Forced Always-On Mode:** The AOM forces continuous signal output regardless of external or internal signals.

Notes:

Due to asynchronous timing between external input signals and internal laser signals, the laser output pulses may jitter by up to one period of the laser repetition frequency relative to input signals. To eliminate this effect and match mainstream drive boards, the three Trigger modes adopt different internal algorithms. Select the proper mode based on actual performance. The frequency of the external input Trigger signal must be lower than the set laser repetition frequency.

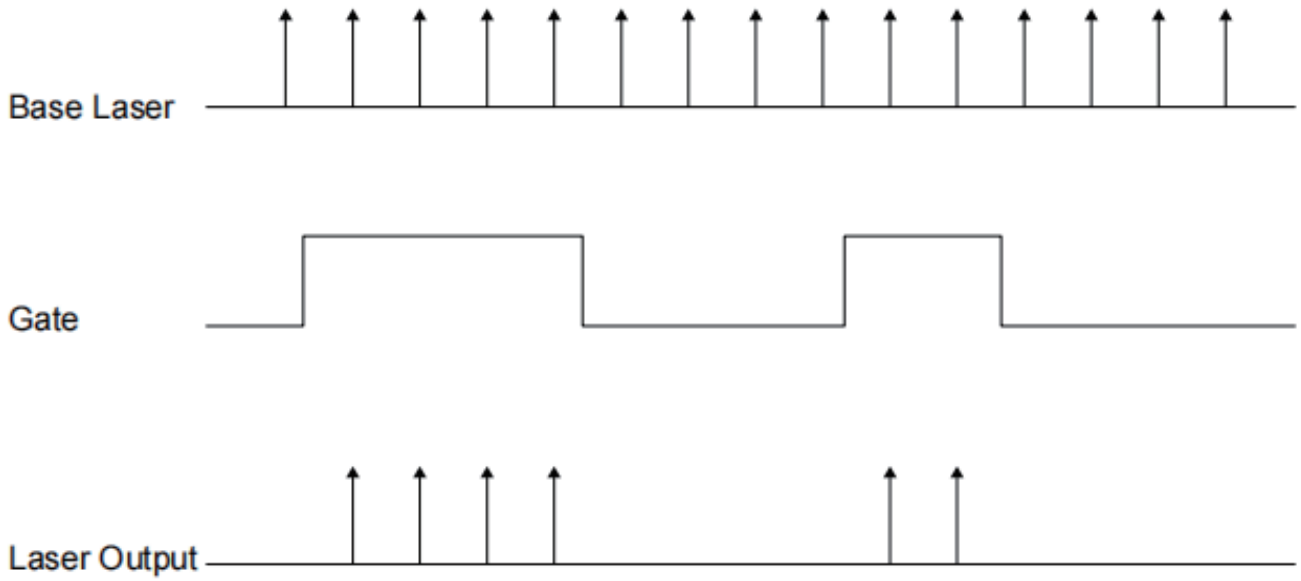

*Gate Timing Diagram

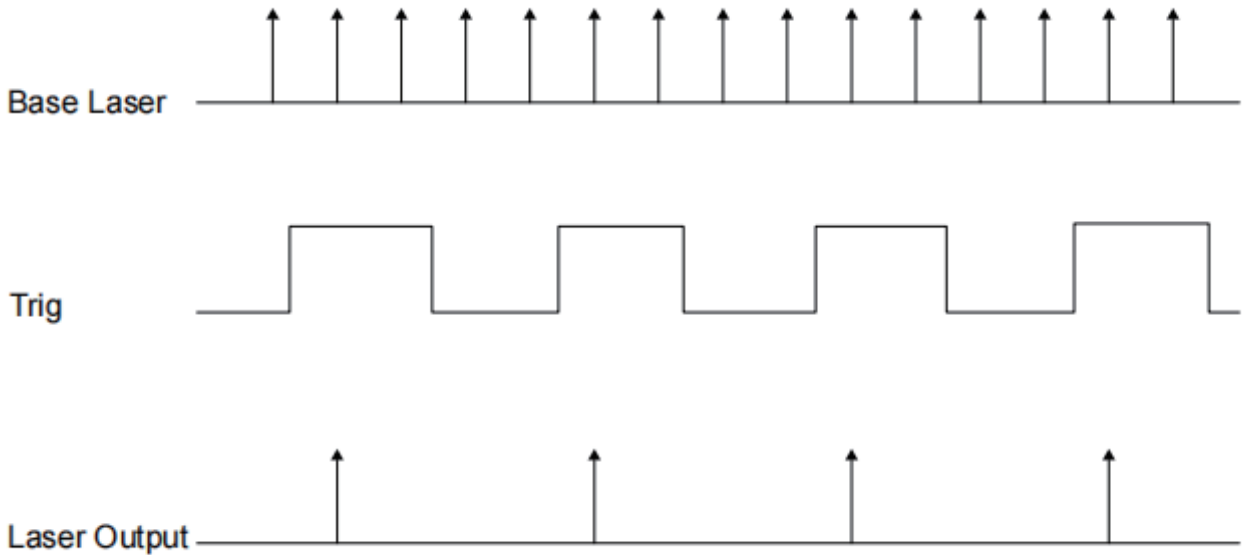

*Trigger Timing Diagram

8.Laser Signal Connection with Control Card

LASER SIGNAL CONNECTION WITH CONTROL CARD I/O

8.1 Integrated System Signal Connection

Laser Control Interface

Golden Orange Marking Control Card DB15 Interface

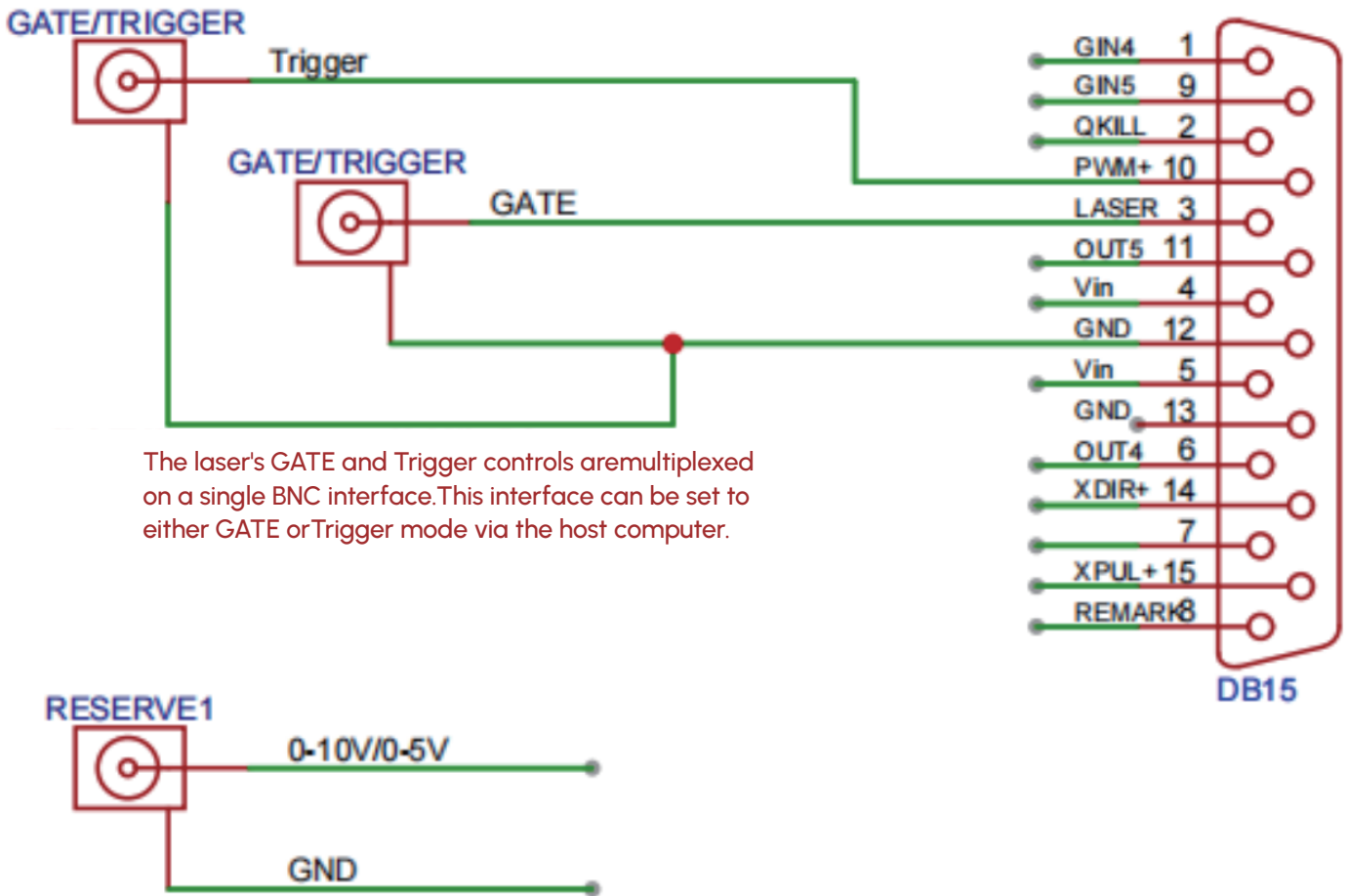

The laser's GATE and Trigger controls are multiplexed on a single BNC interface. This interface can be set to either GATE or Trigger mode via the host computer.

RESERVE1 of the laser serves as an analog power regulation interface. The power control mode can be set on the host computer to internal control/ external 0-10V / external 0-5V. The use of external power regulation requires the machine control board to support this function.

*Example 1

Laser Control Interface

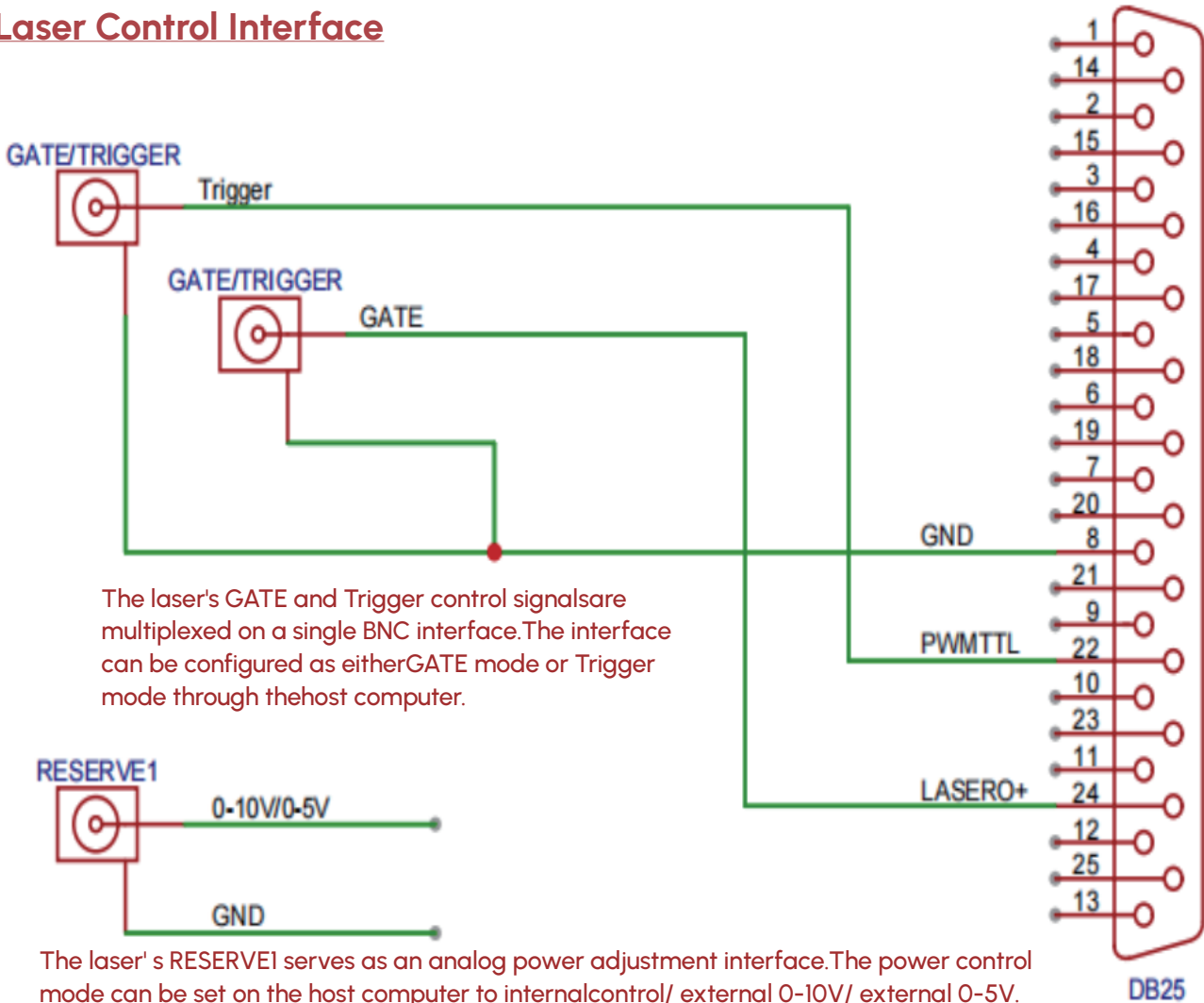

*Example 2

8.2 Split-type System Signal Connection

For the split-type unit, GATE and TRIGGER are two independent BNC interfaces. When the processing mode is set to GATE or TRIGGER mode via the host software, the connected hardware interface must be consistent with the selected mode on the host.

9. Host Software Operation

a. The software program is stored in the USB flash drive delivered with the equipment. Two versions (Standard Version and Lite Version) have been developed to meet customer requirements. If no specific version is specified, use the one provided upon delivery. The software is updated irregularly; please contact our sales personnel to obtain the latest version.

b. Due to incomplete system drivers and runtime libraries, some PCs may fail to launch the software with prompts such as C++ runtime error. It is recommended to update the C++ runtime libraries of the operating system.

c. Connect the laser to the PC using the supplied serial-port cable.

d. Double-click the software icon or right-click to run the application as Administrator, then enter the following connection interface.

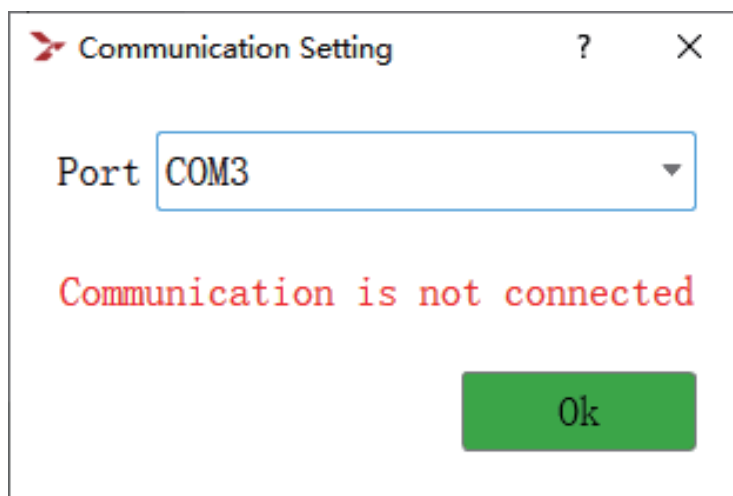

e. Only E-STOP and INTERLOCK are enabled by default. The other functions described above are customer-specific customizations. Please confirm with our sales personnel in advance if you need to enable these functions or customize other functions!

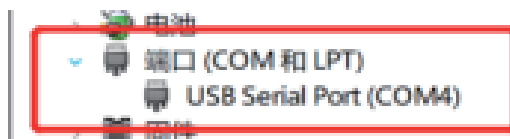

f. Select the correct port number, connect to the laser, and enter the user interface.

*Standard-Version Software

The screenshot displays the LSRHMI software interface with the following details:

- Operation Area:**
 - Repeat Frequency (kHz): 100, 1
 - Burst: 1, 1
 - Pulse width (ps): Fixed, 3
 - AOM2 Power: IntervalPer, 4.00, 4
 - Frequency (kHz): 100, 100
 - Control Mode: Internal Cc
 - Shutter: OFF
 - HMI Emergency Stop: ON
 - Dehumidification: OFF
 - Laser Switch: 0%
 - AOM2 Power: 65.536 W
 - correctio: 0.1
 - SHG Controller: SHG (°C) 25.5, THG (°C) 26.5
- State And Frequency Doubling:**
 - Main Controller Communication:
 - Sensor Communication:
 - Function Module Communication:
 - Function Module State:
 - Emergency Stop State:
 - Interlock:
 - AOM2 Standby Model:
 - X1:
 - Dehumidification Pump:
 - AOM2 Trigger Model:
 - X2:
 - AOM2 Shutter:
 - AOM2 Gate Model:
 - X3:
 - Y2:
 - AOM2 Internal Control Model:
 - Y1:
 - Y3:
- Base Info:**
 - P/N: 0, S/N: H26UTNA090001, Machine Model: [Empty]
 - Firmware Version: 1.7.0, Hardware Version: 1.2.61, Software Version: 1.14.6
 - Recommended Water Temperature: 22.5 (°C)
 - Recommended Water Flow: 6.5 (L/min)
- Status Bar:**
 - Auto trigger Emergency Stop (HMI)
 - 2 MCU bus error
 - Alarm Code: 3 MCU unknown instruction error

The updated host software adds Internal Percentage Adjustment, External 0-10V, and External 0-5V for power adjustment. These correspond to the RESERVE interface of the split-type unit and the RESERVE1 interface of the integrated unit mentioned above.

The screenshot displays the updated LSRHMI software interface with the following details:

- Operation Area:**
 - Repeat Frequency (kHz): 100, 1
 - Burst: 10, 10
 - Pulse width (ps): Fixed, 0
 - AOM2 Power: IntervalPer, 4.00, 4
 - Frequency (kHz): 100, 100
 - Control Mode: Trigger, PST
 - Shutter: OFF
 - HMI Emergency Stop: ON
 - Dehumidification: OFF
 - Laser Switch: 0%
 - AOM2 Power: 65.536 W
 - correctio: 0.1
 - SHG Controller: SHG (°C) 25.5, THG (°C) 26.5
- State And Frequency Doubling:**
 - Main Controller Communication:
 - Sensor Communication:
 - Function Module Communication:
 - Function Module State:
 - Emergency Stop State:
 - Interlock:
 - AOM2 Standby Model:
 - X1:
 - Dehumidification Pump:
 - AOM2 Trigger Model:
 - X2:
 - AOM2 Shutter:
 - AOM2 Gate Model:
 - X3:
 - Y2:
 - AOM2 Internal Control Model:
 - Y1:
 - Y3:
- Base Info:**
 - P/N: 0, S/N: H25IRPA060018, Machine Model: [Empty]
 - Firmware Version: 1.7.0, Hardware Version: 1.2.61, Software Version: 1.17.0
 - Recommended Water Temperature: 22.5 (°C)
 - Recommended Water Flow: 6.5 (L/min)
- Status Bar:**
 - Auto trigger Emergency Stop (HMI)
 - Alarm Code: 4096 数据Flash初始化失败
 - Alarm Code: 2 MCU总线错误

The figure below shows the dual-laser-head version. Only AOM2 is operable for the single-head laser.

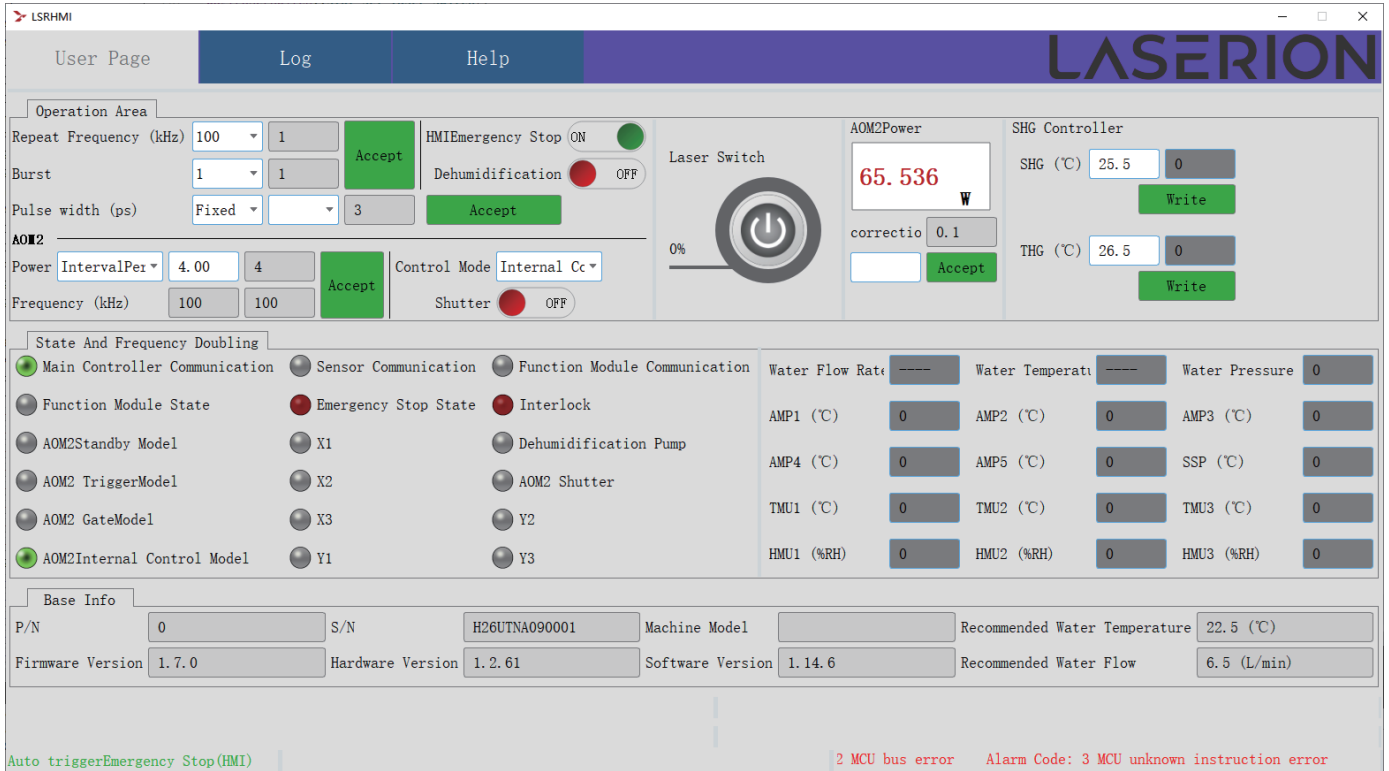

The screenshot displays the LSRHMI control interface. At the top, there are navigation tabs for 'User Page', 'Log', and 'Help', along with the 'LASERION' logo. The main interface is divided into several sections:

- Operation Area:** Contains laser parameter configuration fields such as Repeat Frequency (kHz), Burst, Pulse width (ps), AOM2 Power, and SHG Controller settings. It also includes a Laser Switch control and an AOM2 Power display showing 65.536 W.
- State And Frequency Doubling:** A grid of status indicators for various communication and sensor states, including Main Controller Communication, Sensor Communication, Function Module Communication, and various communication models (AOM2Standby, Trigger, Gate, Internal Control).
- Base Info:** Displays system information such as P/N, S/N, Machine Model, Firmware Version, Hardware Version, Software Version, Recommended Water Temperature, and Recommended Water Flow.
- Alerts:** A status bar at the bottom shows error messages: 'Auto triggerEmergency Stop(HMI)', '2 MCU bus error', and 'Alarm Code: 3 MCU unknown instruction error'.

Main Operation Area: Mainly used for laser parameter configuration and operation.

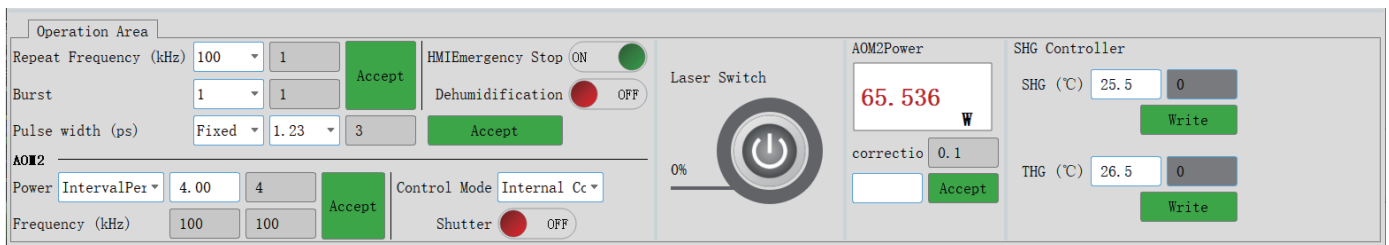

This close-up view of the main operation area shows the following details:

- Parameter Inputs:** Repeat Frequency (100 kHz), Burst (1), Pulse width (Fixed, 1.23 ps), AOM2 Power (4.00), and SHG Controller (SHG: 25.5 °C, THG: 26.5 °C).
- Control Elements:** Laser Switch (0%), AOM2 Power display (65.536 W), and various 'Accept' and 'Write' buttons.
- Status Indicators:** HMI Emergency Stop (ON), Dehumidification (OFF), and Shutter (OFF).

Status Feedback Area: Mainly used to display partial status of the laser and feedback from sensors.

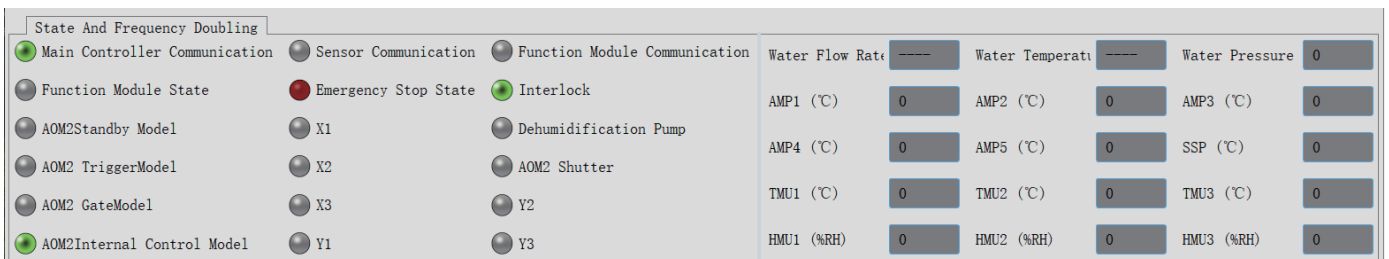

This close-up view of the status feedback area shows the following details:

- Communication Status:** Main Controller Communication (ON), Sensor Communication (OFF), Function Module Communication (OFF).
- Emergency States:** Emergency Stop State (OFF), Interlock (ON).
- Sensor Readings:** Water Flow Rate, Water Temperature, Water Pressure, and various temperature (AMP1-5, TMU1-3) and humidity (HMU1-3) sensors, all showing 0.

Basic Information Area: Mainly displays the laser's SN and version information.

Base Info							
P/N	0	S/N	H26UTPA090001	Machine Model		Recommended Water Temperature	22.5 (°C)
Firmware Version	1.7.0	Hardware Version	1.2.61	Software Version	1.14.5	Recommended Water Flow	6.5 (L/min)

Auto trigger Emergency Stop(HMI) | 度异常触发急停 Alarm Code: 4096 数据Flash初始化失败 Alarm Code

g. Select the laser repetition frequency and Burst mode, then set the parameters.

Repeat Frequency (kHz)	100	1	Accept
Burst	1	1	

h. Click the laser power-on button on the host software.

If the laser fails to meet startup conditions, a pop-up prompt will appear on the host. Troubleshoot accordingly, then click the laser power-on button again to enable laser emission.

LSRHMI ? X

Interlock locked, unable to turn on laser!
 Please check if the hardware interlock signal is disconnected (signal wire not shorted, machine disconnected, etc.)!
 Please check if the sensor status and device status are within the normal working range!
 Please check if the emergency stop has been triggered!

OK

i. Wait for the laser to start up; the progress bar displays the current startup progress.

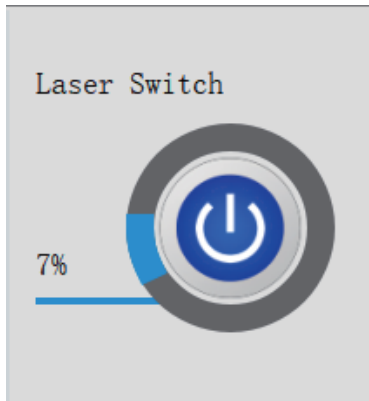

*Starting up

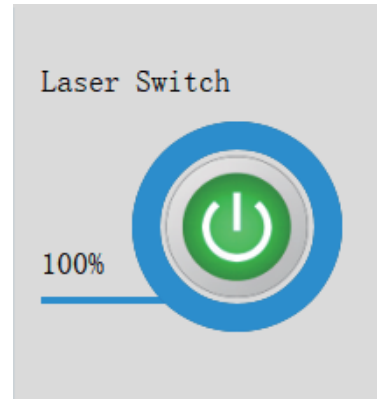

*After the laser is switched on

j. Select the control mode for the AOM.

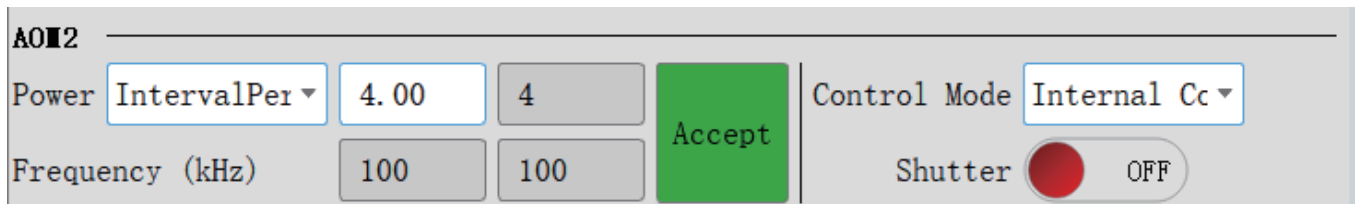

When Gate mode is selected, the AOM frequency (frequency division) can be set, and the divided frequency must be lower than the preset laser frequency.

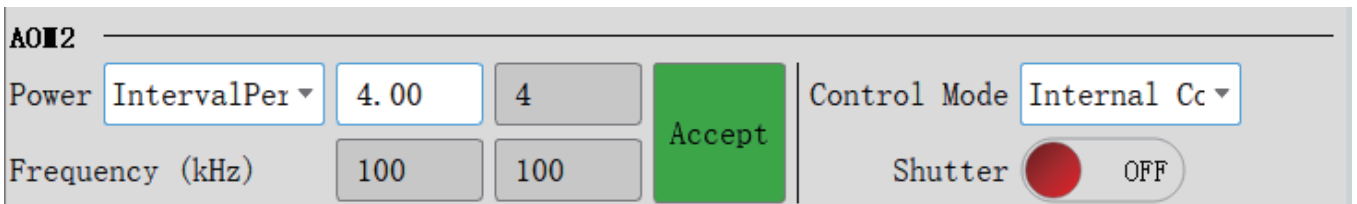

When any Trigger mode is selected, processing parameters (processing speed, point-to-point distance, compensation value) can be set. Update the recommended processing speed; it is recommended to perform processing using the recommended value.

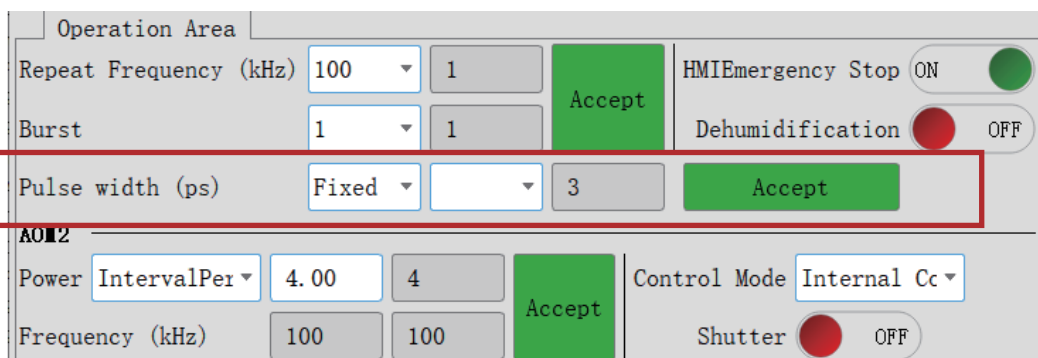

When any Trigger mode is selected, processing parameters (processing speed, point-to-point distance, compensation value) can be set.

Update the recommended processing speed; it is recommended to perform processing using the recommended value. To select the PST mode, click the [Normal] button in Trigger mode, then choose [PST] to successfully switch to PST mode.

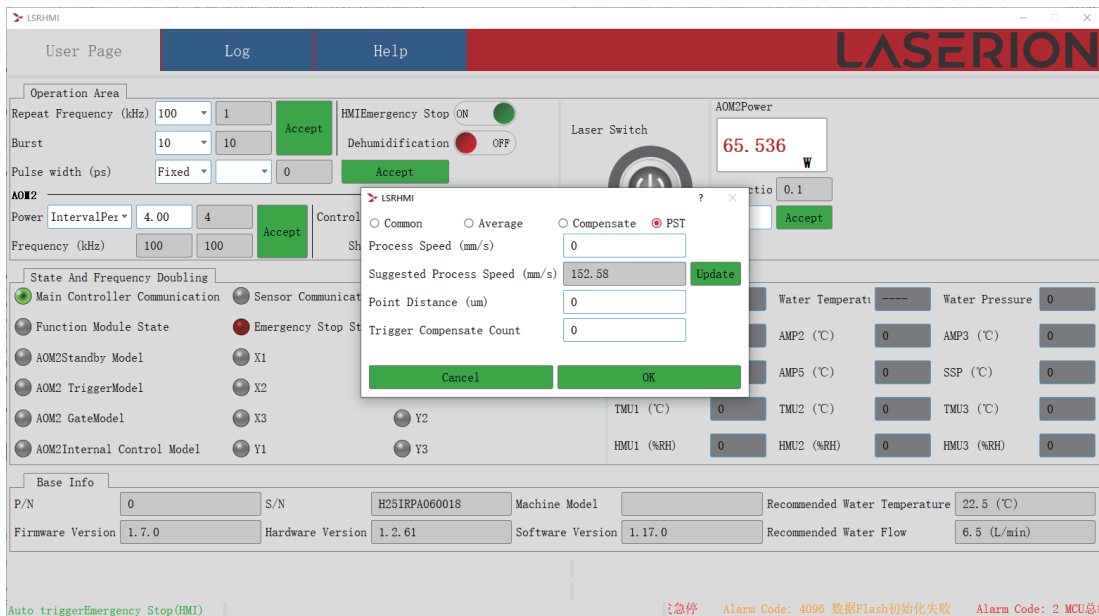
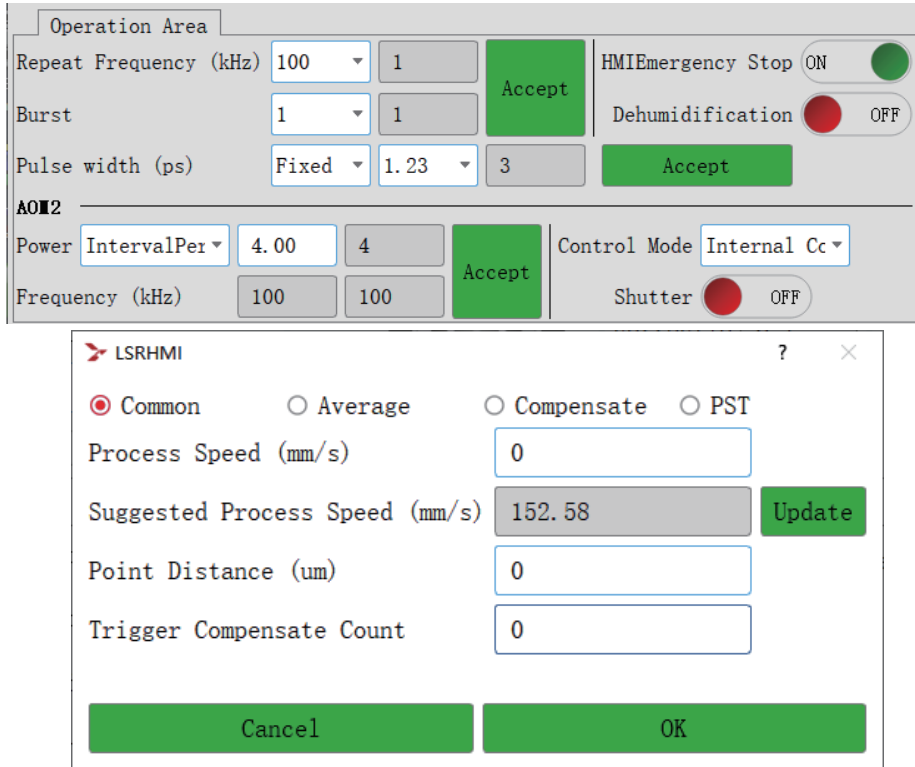

k. Set the laser output power percentage and open the AOM Shutter. The laser will emit laser according to the selected mode.

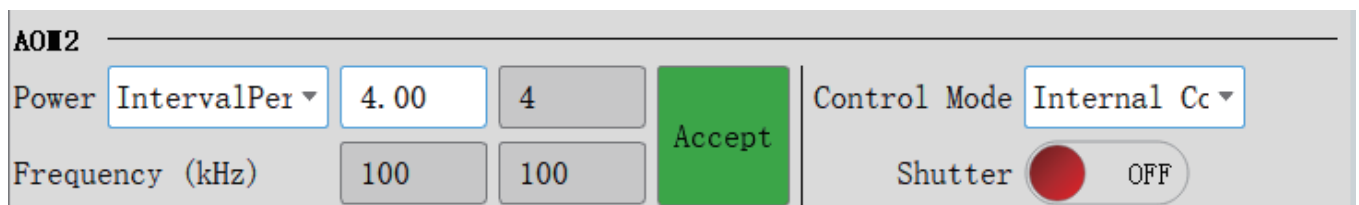

L.Laser Shutdown

With the laser powered-on, click the laser switch button on the host software to shut down the laser. The progress bar displays the reverse shutdown progress.

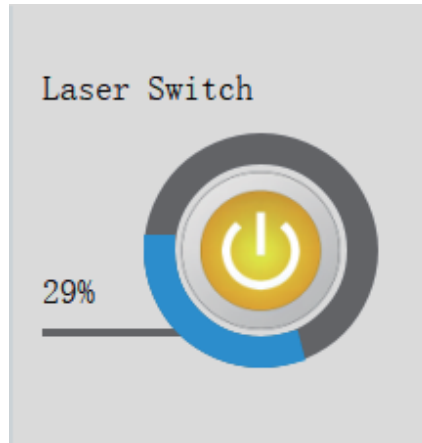

m.Frequency-doubling Control Description

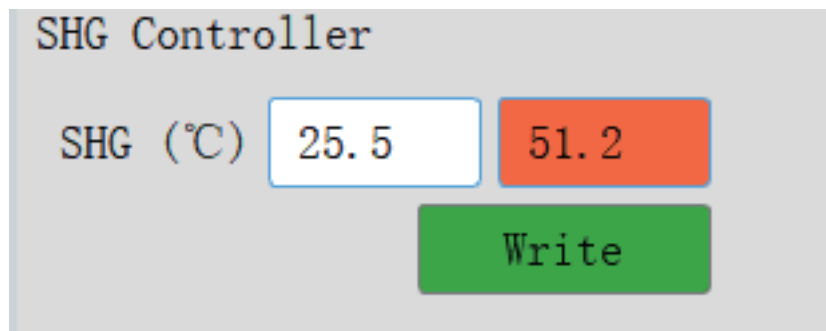

The left box shows the set temperature, and the right box shows the current temperature. An orange background for the current temperature indicates heating is in progress, while a blue background indicates cooling is in progress.

* The frequency-doubling temperature has been optimized before laser delivery. Do not adjust it arbitrarily.

n.Log Query

Alarm Record Query: Used to view current and historical alarm records.

* Current Alarms:

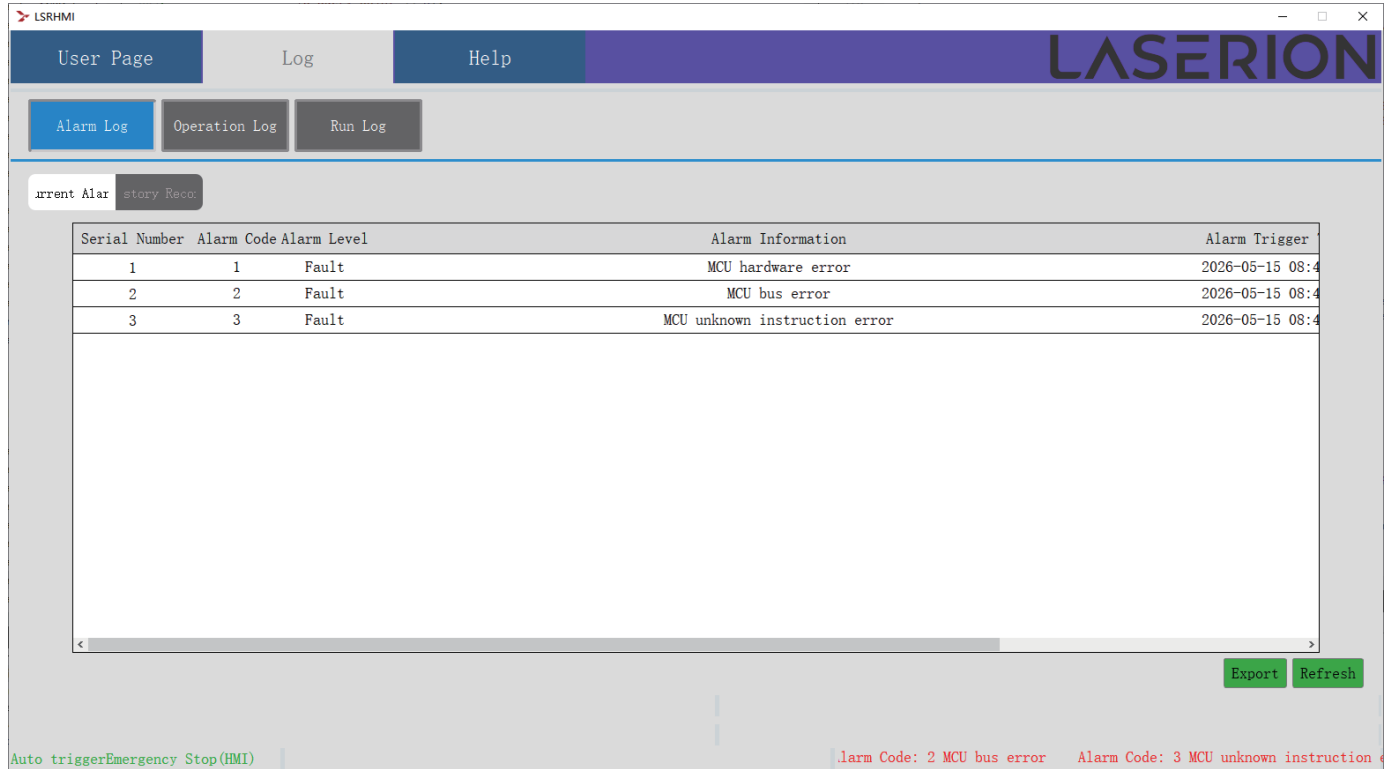

Serial Number	Alarm Code	Alarm Level	Alarm Information	Alarm Trigger
1	1	Fault	MCU hardware error	2026-05-15 08:41:24
2	2	Fault	MCU bus error	2026-05-15 08:41:24
3	3	Fault	MCU unknown instruction error	2026-05-15 08:41:24

Auto triggerEmergency Stop(HMI) | Alarm Code: 2 MCU bus error Alarm Code: 3 MCU unknown instruction error

* Historical Alarms:

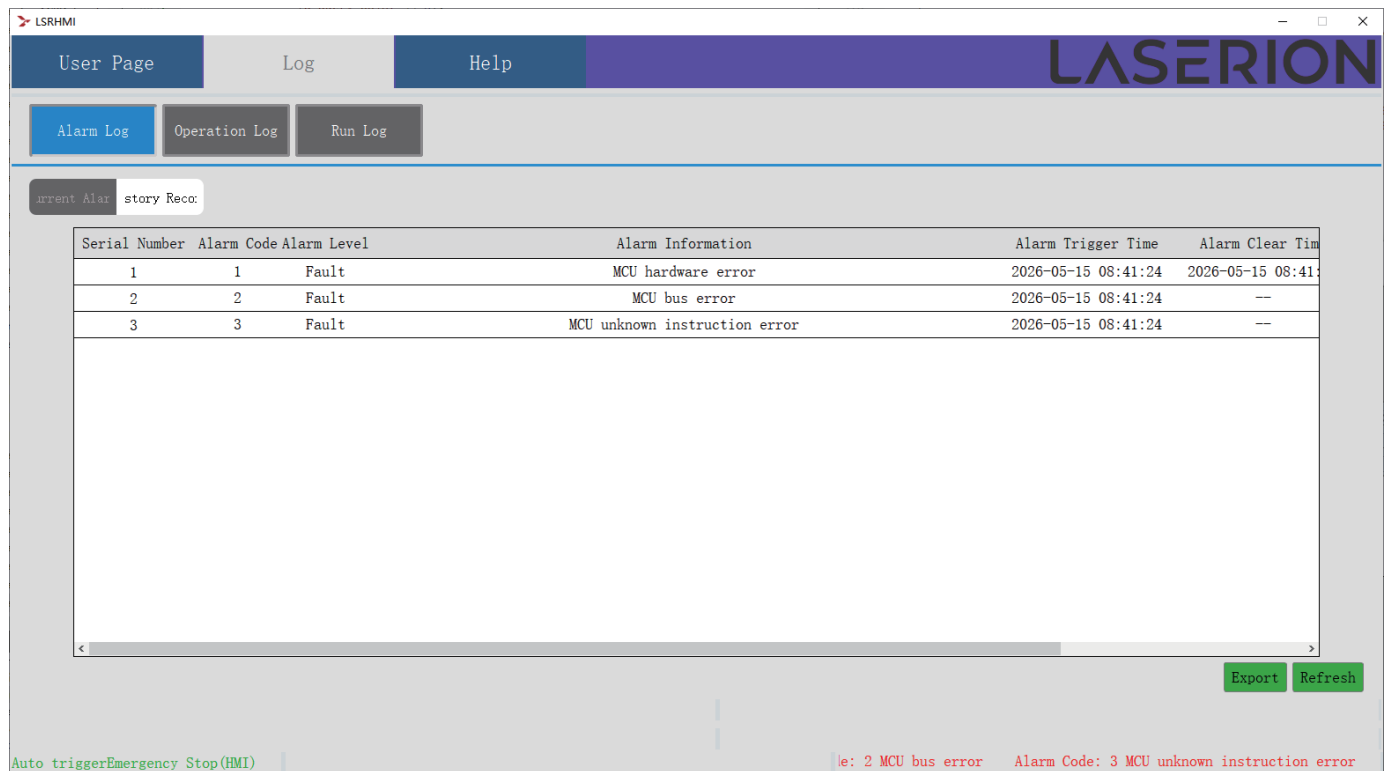

Serial Number	Alarm Code	Alarm Level	Alarm Information	Alarm Trigger Time	Alarm Clear Time
1	1	Fault	MCU hardware error	2026-05-15 08:41:24	2026-05-15 08:41:24
2	2	Fault	MCU bus error	2026-05-15 08:41:24	--
3	3	Fault	MCU unknown instruction error	2026-05-15 08:41:24	--

Auto triggerEmergency Stop(HMI) | Alarm Code: 2 MCU bus error Alarm Code: 3 MCU unknown instruction error

* Operation Log:

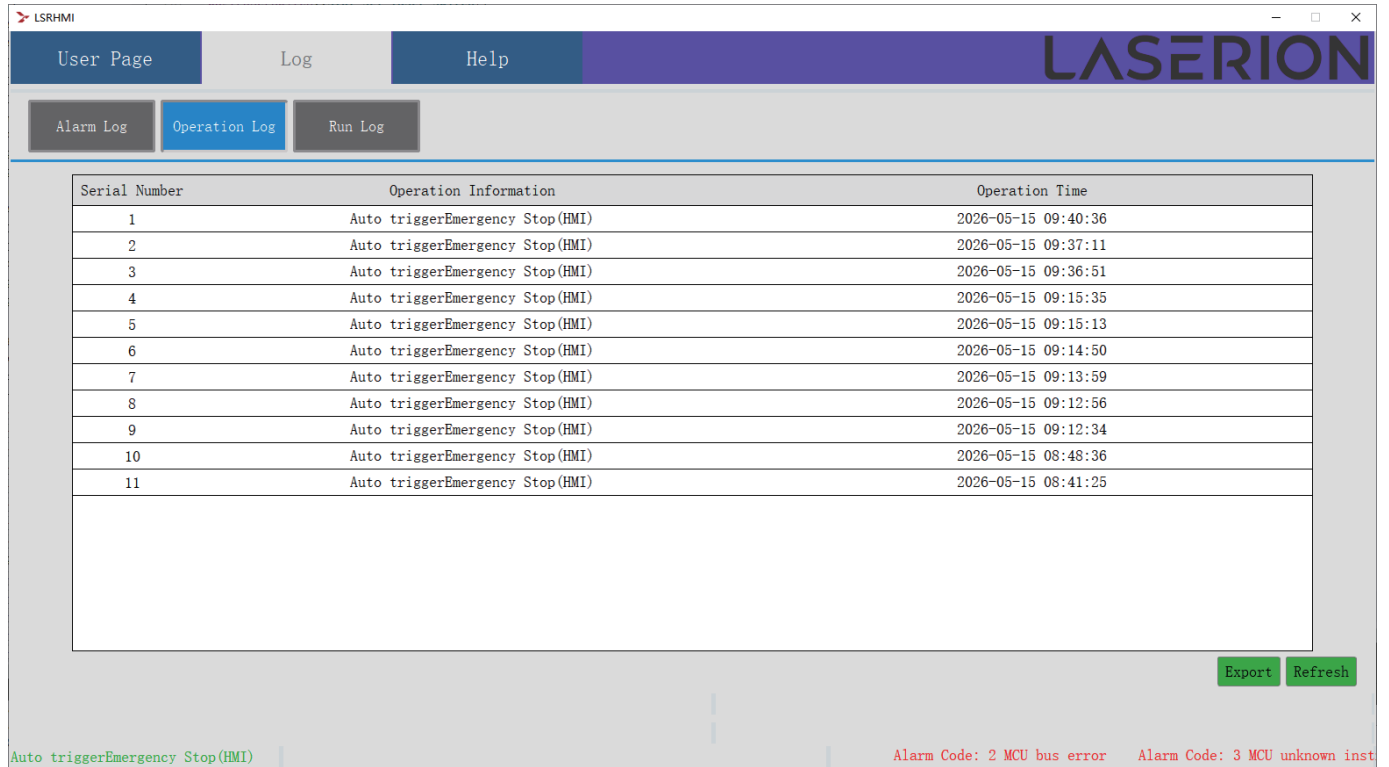

Serial Number	Operation Information	Operation Time
1	Auto triggerEmergency Stop (HMI)	2026-05-15 09:40:36
2	Auto triggerEmergency Stop (HMI)	2026-05-15 09:37:11
3	Auto triggerEmergency Stop (HMI)	2026-05-15 09:36:51
4	Auto triggerEmergency Stop (HMI)	2026-05-15 09:15:35
5	Auto triggerEmergency Stop (HMI)	2026-05-15 09:15:13
6	Auto triggerEmergency Stop (HMI)	2026-05-15 09:14:50
7	Auto triggerEmergency Stop (HMI)	2026-05-15 09:13:59
8	Auto triggerEmergency Stop (HMI)	2026-05-15 09:12:56
9	Auto triggerEmergency Stop (HMI)	2026-05-15 09:12:34
10	Auto triggerEmergency Stop (HMI)	2026-05-15 08:48:36
11	Auto triggerEmergency Stop (HMI)	2026-05-15 08:41:25

Status Bar: Auto triggerEmergency Stop (HMI) | Alarm Code: 2 MCU bus error | Alarm Code: 3 MCU unknown inst

* Operation Log:

Runtime Log: Partial runtime records are available for query at present.

Simplified-version Software

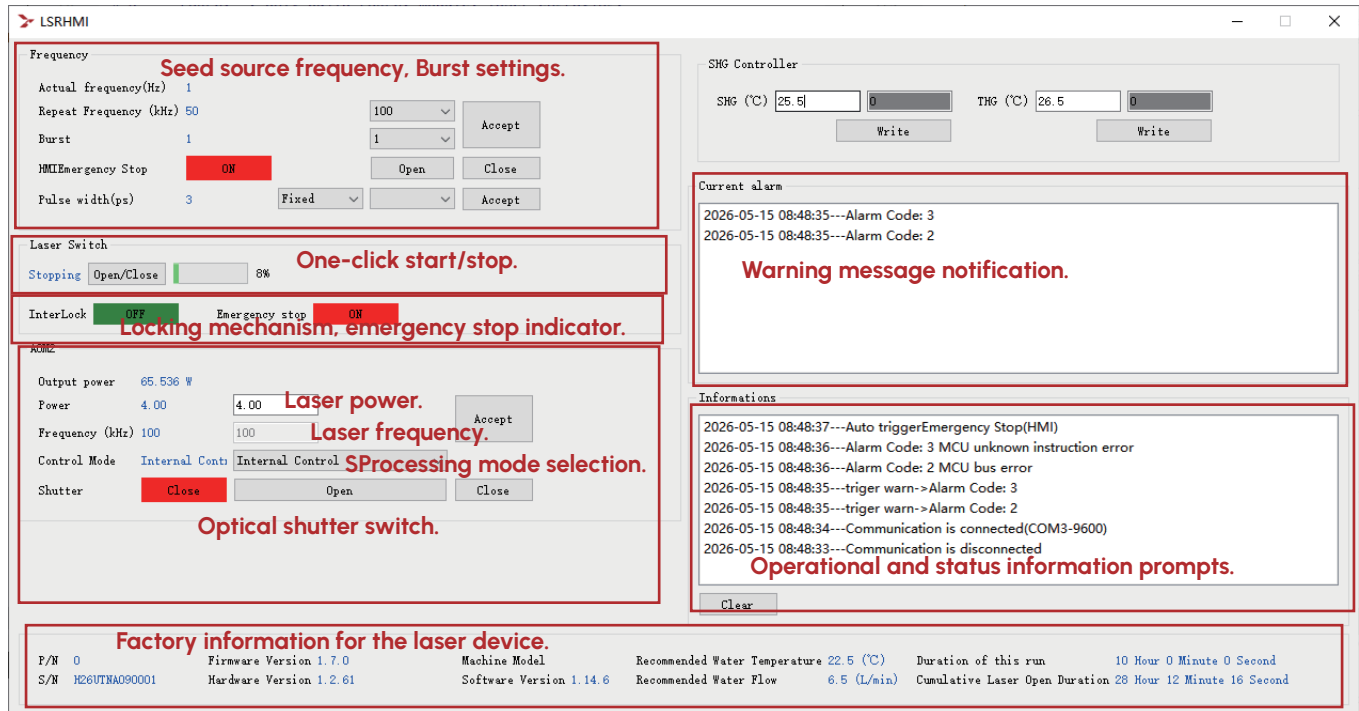

The relevant operation logic is consistent with that of the standard version.

- *Select the corresponding COM port number to enter the interface.
- *Check interlock and emergency-stop indicators as well as alarm prompts; contact our company in case of faults.
- *It is recommended to set the laser power to 1% and switch the shutter to OFF before laser emission.
- *Set the seed source frequency and Burst within the permitted range specified in the factory test report, then click OK.
- *One-click to start the laser, and wait until the startup progress reaches 100%.
- *Select Internal Control as the processing mode, and switch the shutter to ON under safe conditions.
- *The laser starts emitting light; inspect the laser spot at the output port.
- *After optical path debugging, select the processing mode (GATE/TRIGGER) as required.

10. Fault Codes & Troubleshooting Fault Codes & Troubleshooting

Fault Code	Fault Name	Possible Causes / Solutions
N/A	Slave Computer Communication Interruption	Possible Cause: Communication breakdown or data parsing error between PC and electric control box Solutions: 1. Check connection cables and correct COM port; 2. Update master computer software version
9216	Slave Computer Does Not Support Current HMI Version	Possible Cause: Master computer version incompatible Solutions: 1. Restart master computer software; 2. Update master computer version
10496	Hardware Emergency Stop Triggered	Possible Cause: Emergency stop button pressed or external emergency-stop signal disconnected Solution: Restore emergency-stop switch to normal state
10497	HMI Software Emergency Stop Triggered	Possible Cause: HMI software emergency stop enabled Solution: Disable HMI software emergency stop

9730 / 10498	Emergency Stop Triggered by Abnormal Seed-source Temperature	<p>Possible Cause: Abnormal seed/source temperature or sensor failure</p> <p>Solution: Check the temperature value displayed on the software interface and contact after-sales personnel</p>
9731 / 10499	Emergency Stop Triggered by Abnormal Pump-source Temperature	<p>Possible Cause: Abnormal pump-source temperature or sensor failure</p> <p>Solution: Check the temperature value displayed on the software interface and contact after-sales personnel</p>
9734 / 10502	Emergency Stop Triggered by Abnormal Water Flow	<p>Possible Cause: Abnormal water flow or sensor failure</p> <p>Solutions: 1.Check if the chiller water flow is normal; 2.Check whether water pipes are properly connected (avoid reversed inlet/outlet pipes); Check the flow value displayed on the software interface and contact after-sales personnel</p>
9736-9752	Abnormal Monitoring System, Unreliable Sensor Data	<p>Possible Cause: Sensor failure</p> <p>Solution: Check the data displayed on the software interface and contact after-sales personnel</p>